



RULES FOR

**MATERIALS AND WELDING
2014**

**PART 2
ALUMINUM and FIBER REINFORCED PLASTICS (FRP) (CHAPTERS 5-6)**

**American Bureau of Shipping
Incorporated by Act of Legislature of
the State of New York 1862**

**Copyright © 2013
American Bureau of Shipping
ABS Plaza
16855 Northchase Drive
Houston, TX 77060 USA**

Rule Change Notice (2014)

The effective date of each technical change since 1993 is shown in parentheses at the end of the subsection/paragraph titles within the text of each Part. Unless a particular date and month are shown, the years in parentheses refer to the following effective dates:

(2000) and after	1 January 2000 (and subsequent years)	(1996)	9 May 1996
(1999)	12 May 1999	(1995)	15 May 1995
(1998)	13 May 1998	(1994)	9 May 1994
(1997)	19 May 1997	(1993)	11 May 1993

Listing by Effective Dates of Changes from the 2013 Rules

EFFECTIVE DATE 1 January 2014 – shown as (2014)

(based on the contract date for new construction between builder and Owner)

<i>Part/Para. No.</i>	<i>Title/Subject</i>	<i>Status/Remarks</i>
2-5-1/1.1	General	To align the requirements with IACS UR W25, Rev. 4.
2-5-1/5.1	Form of Certificate	To align the requirements with IACS UR W25, Rev. 4.
2-5-5/Table 1A	Mechanical Property Limits of Non-Heat-Treatable Sheet and Plate Aluminum Alloys	To align the requirements with IACS UR W25, Rev. 4.
2-5-6/1	General	To align the requirements with IACS UR W25, Rev. 4.
2-5-6/3	Reference Photomicrograph	To align the requirements with IACS UR W25, Rev. 4.
2-5-6/5	Batch Microstructural Analysis and Acceptance	To align the requirements with IACS UR W25, Rev. 4.
2-5-7/7	Surface Finish	To align the requirements with IACS UR W25, Rev. 4.
2-5-8/7	Surface Finish	To align the requirements with IACS UR W25, Rev. 4.

PART
2

Rules for Materials and Welding – Aluminum and Fiber Reinforced Plastics (FRP)

CONTENTS

CHAPTER 5	Materials for Hull Construction – Aluminum	1
Section 1	General	7
Section 2	Standard Test Materials.....	11
Section 3	Chemical Composition	12
Section 4	Heat Treatment	14
Section 5	Tensile Properties	15
Section 6	Corrosion Testing.....	25
Section 7	Sheet, Plate and Rolled Products	27
Section 8	Extrusions	29
Section 9	Forgings	32
Section 10	Castings	34
Section 11	Rivets	36
Appendix 1	Aluminum Welding in Hull Construction.....	37
Appendix 2	Requirements for the Approval of Aluminum Filler Metals	65
Appendix 3	Scheme for the Approval of Aluminum Manufacturers	70
CHAPTER 6	Materials for Hull Construction – Fiber Reinforced Plastics (FRP)	73
Section 1	General	77
Section 2	Fabrication	83
Section 3	Building Process Description	85
Section 4	Quality Control	95
Section 5	Testing	102
Section 6	Repair	104

This Page Intentionally Left Blank

PART
2

CHAPTER **5** **Materials for Hull Construction – Aluminum**

CONTENTS

SECTION 1	General	7
1	Testing and Inspection.....	7
1.1	General.....	7
1.3	Witnessed Tests.....	7
1.5	Rejection of Previously Accepted Material	7
1.7	Calibrated Testing Machines.....	7
1.9	Referenced Documents.....	8
3	Defects.....	8
5	Manufacturer’s Certificates	8
5.1	Form of Certificate.....	8
5.3	Other Certificates	9
5.5	Dual Certification	9
5.7	Electronic Certification System.....	9
7	Identification Markings	9
7.1	Marine Grades.....	9
7.3	Material Identification	10
7.5	Stenciled Material.....	10
SECTION 2	Standard Test Methods	11
1	General	11
1.1	Chemical Analysis	11
1.3	Tension Testing.....	11
1.5	Shear Testing.....	11
1.7	Hardness Testing	11
1.9	Electrical Conductivity Testing.....	11
SECTION 3	Chemical Composition	12
1	General	12
3	Sampling	12
5	Definition of an Inspection Lot	12
TABLE 1	Chemical Composition Limits of Wrought Aluminum Alloys.....	13
TABLE 2	Chemical Composition Limits of Cast Aluminum Alloys	13
SECTION 4	Heat Treatment	14

SECTION 5	Tensile Properties	15
1	General	15
3	Yield Strength	15
5	Standard Test Specimens	15
5.1	General	15
5.3	Full-Section Specimens	15
5.5	Machined Specimens	15
5.7	Dimensions	16
5.9	Test Specimens Orientation and Location	17
7	Retests	17
7.1	Defective Test specimen	17
7.3	Failure to Meet Requirements	17
TABLE 1A	Mechanical Property Limits of Non-Heat-Treatable Sheet and Plate Aluminum Alloys	18
TABLE 1B	Mechanical Property Limits of Non-Heat-Treatable Marine Grade Sheet and Plate Aluminum Alloys for Hull Construction	19
TABLE 2	Long Transverse Mechanical Property Limits of Heat-Treatable Sheet and Plate Aluminum Alloys	20
TABLE 3	Longitudinal Mechanical Property Limits of Non-Heat-Treatable Aluminum Alloys for Extruded Bars, Rods, Shapes, and Tubes	21
TABLE 4	Mechanical Property Limits of Heat-Treatable Aluminum Alloys for Extruded Products	21
TABLE 5	Mechanical Property Limits for Die Forgings	22
TABLE 6	Mechanical Property Limits for Hand Forgings	23
TABLE 7	Mechanical Property Limits for Aluminum Alloy Castings	23
TABLE 8	Aluminum Alloy Equivalents	24
FIGURE 1	Standard Tension Test Specimen	16
SECTION 6	Corrosion Testing	25
1	General	25
3	Reference Photomicrograph	25
5	Batch Microstructural Analysis and Acceptance	25
7	Surveillance of Corrosion Testing	26
SECTION 7	Sheet, Plate and Rolled Products	27
1	Scope	27
3	Selection of Tension Test Specimen	27
5	Number of Tension Tests	27
5.1	Sheet	27
5.3	Plate and Rolled Products	27
5.5	Definition of a Batch	27
7	Surface Finish	28
9	Nondestructive Examination (NDE)	28

11	Dimensions and Tolerance	28
TABLE 1	Under-thickness Tolerance for Rolled Products	28
SECTION 8	Extrusions.....	29
1	Scope	29
3	Selection of Specimens	29
5	Number of Tests	29
5.1	Tension Tests.....	29
5.3	Drift Expansion Tests	29
5.5	Definition of a Batch	30
7	Surface Finish	30
9	Nondestructive Examination (NDE)	30
11	Dimensions and Tolerance	31
FIGURE 1	Drift Expansion Test.....	30
SECTION 9	Forgings.....	32
1	Scope	32
3	Selection of Specimens	32
3.1	Location of Specimens	32
3.3	Small Forgings	32
3.5	Test Specimens.....	32
5	Number of Tests	32
5.1	Large Forgings	32
5.3	Smaller Forgings	32
5.5	Small Forgings	33
5.7	Special Situations	33
7	Inspection.....	33
9	Nondestructive Examination (NDE)	33
11	Dimensions and Tolerance	33
SECTION 10	Castings.....	34
1	Scope	34
3	Selection of Specimens	34
3.1	Large Castings	34
3.3	Small Castings	34
3.5	Test Specimens.....	34
5	Number of Tests	34
7	Inspection.....	34
9	Welded Repair of Defects	35
11	Nondestructive Examination (NDE)	35
13	Dimensions and Tolerance	35

SECTION 11 Rivets.....	36
1 General	36
 APPENDIX 1 Aluminum Welding in Hull Construction.....	37
1 General	37
1.1 Hull Welding	37
1.3 Plans and Specifications.....	37
1.5 Workmanship and Supervision	37
1.7 Welding Procedures	37
3 Preparation for Welding	37
3.1 Edge Preparation and Fitting	37
3.3 Alignment.....	38
3.5 Cleanliness	39
3.7 Tack Welds.....	39
3.9 Stud Welding	40
3.11 Temporary Back-up Plates and Tapes	40
3.13 Run-on and Run-off Tabs	40
3.15 Forming	40
5 Production Welding.....	41
5.1 Environment	41
5.3 Preheat.....	41
5.5 Postheating.....	42
5.7 Accessibility.....	42
5.9 Sequence	42
5.11 Back Gouging.....	42
5.13 Fairing and Flame Shrinking	42
5.15 Inspection of Welds	42
5.17 Workmanship Requirements	45
5.19 Quality Control.....	46
5.21 Repair Welding.....	46
7 Butt Welds.....	46
7.1 Joint Design.....	46
9 Fillet Welds.....	46
11 Filler Metals.....	46
11.1 General.....	46
11.3 Approval Basis.....	47
13 Approval of Welding Procedures	47
13.1 Approved Filler Metals	47
13.3 Surveyor's Acceptance.....	47
13.5 New Procedures and Methods	47
13.7 Tests.....	47
13.9 Special Tests	47
15 Welder Qualifications	48
15.1 General.....	48
15.3 Qualification Tests	48
17 Alternatives	48

TABLE 1	Minimum Cold-forming Radii for Aluminum Alloys.....	41
TABLE 2	Minimum Mechanical Properties for Butt-Welded Aluminum Alloys.....	49
TABLE 3	Aluminum Alloy Filler Metal Composition	49
TABLE 4	Filler Metals for Welding Aluminum Alloy – Sheet, Plate and Extrusions	50
TABLE 5	Filler Metals for Welding Aluminum Alloy Castings to Castings and Plate	50
TABLE 6	Welder Qualification Tests.....	51
FIGURE 1A	Inserts and Patches in Plating	39
FIGURE 1B	Inserts and Patches in Plating	39
FIGURE 2	Repairs of Misalignments.....	43
FIGURE 3	Permissible Unfairness in Aluminum Welded Structure	51
FIGURE 4	Permissible Unfairness in Other Aluminum Welded Structure.....	52
FIGURE 5	Preparation of Test Plates and Pipes for Weld Tests Nos. 1 and 2.....	53
FIGURE 6	Typical Arrangement of Test Plates for Workmanship Tests in Group B1	55
FIGURE 7	Test No. 1 – Reduced-section Tension Test for Plate	56
FIGURE 8	Test No. 1 – Reduced-section Tension Test for Pipe	57
FIGURE 9	Test No. 2 – Guided Bend Test for Root Bend and Face Bend (Plate or Pipe).....	58
FIGURE 10	Test No. 2 – Guided Bend Test for Side Bend (Plate or Pipe)	58
FIGURE 11	Guided Bend Test Jig	59
FIGURE 12	Alternative Guided Bend Test Jig	59
FIGURE 13	Test No. 3 – Fillet Weld Test.....	60
FIGURE 14	Welder Qualification Test No. Q1	61
FIGURE 15	Welder Qualification Test No. Q2	62
FIGURE 16	Welder Qualification Test No. Q4	63
FIGURE 17	Welder Qualification Test No. Q5	64

APPENDIX 2	Requirements for the Approval of Aluminum Filler Metals	65
1	General	65
	1.1 Scope	65
	1.3 Grading, Designation.....	65
	1.5 Manufacture, Testing and Approval Procedure	66
3	Testing and Required Properties	66
	3.1 Testing of the Deposited Weld Metal.....	66
	3.3 Testing of Butt Weld Assemblies.....	67
5	Annual Check Tests.....	69

TABLE 1	Consumable Grades and Base Materials for the Approval Test	65
TABLE 2	Compositional Limits of Shielding Gases and Mixtures to be Used	66
TABLE 3	Requirements for the Transverse Tensile and Bend Tests	69
FIGURE 1	Deposited Weld Metal Test Assembly	66
FIGURE 2	Butt Weld Test Assembly for Out-of-position Welding	67
FIGURE 3	Butt Weld Test Assembly in Flat Position	68

APPENDIX 3	Scheme for the Approval of Aluminum Manufacturers.....	70
1	Scope	70
3	Approval Application	70
3.1	Initial Approval	70
3.3	Content of Application.....	70
3.5	Information and Data Required for Approval	70
3.7	Superior Properties.....	72
3.9	ABS Activity in the Approval Process	72
5	Renewal of Approval	72

PART

2

CHAPTER **5** **Materials for Hull Construction – Aluminum**

SECTION **1** **General**

1 **Testing and Inspection**

1.1 **General (2014)**

All materials subject to test and inspection, intended for use in the construction of the hulls of craft classed or proposed for classification, are to be tested by the material producer and inspected by the ABS Surveyor in accordance with the following requirements or their equivalent. These requirements are not applicable to the use of aluminum alloys at low temperature for cryogenic applications. Materials, test specimens and mechanical testing procedures having characteristics differing from those prescribed herein may be approved for application, with due regard being given to established practices in the country in which the material is produced and the purpose for which the material is intended, such as the parts for which it is to be used, the type of craft and intended service, and the nature of the construction of the craft. The requirements are based on both metric and U.S. customary units. Each system of units is to be treated as separate and independent from the other. Mixing and matching of units from one system to another are not permitted. The numerical designation (grade) of aluminum alloys and the temper designation are based on those of the Aluminum Association or recognized Standards.

Consideration may be given to aluminium alloys not specified in these requirements, and to alternative temper conditions, subject to prior agreement with ABS further to a detailed study of their properties, including corrosion resistance, and of their conditions of use (in particular welding procedures).

All materials, including semi-finished products are to be manufactured at works which are approved by ABS for the grades and maximum thickness of aluminum alloy supplied.

1.3 **Witnessed Tests**

All tests are to be carried out by competent personnel and conducted in the presence of the Surveyors at the place of manufacture prior to shipping. Consideration will be given to the acceptance of rolled and extruded products without witnessing of mechanical tests by the Surveyor, on the basis of compliance with ABS's Quality Assurance Program. Testing procedures are to follow established practices in international or national Standards. Test samples are to be taken from material which has undergone the same treatment as the material to be certified. Preparation of specimens is not to involve significant straining or heating. Thermally cut samples are to have excess material to allow a specimen to be machined from material that is unaffected by the cutting process.

1.5 **Rejection of Previously Accepted Material**

In the event of any material proving unsatisfactory in the process of being worked, it shall be rejected, notwithstanding any previous certificate of satisfactory testing.

1.7 **Calibrated Testing Machines**

All testing machines shall be maintained in good condition by the manufacturer and to the satisfaction of the attending Surveyor. The measuring equipment and machinery used shall be periodically calibrated by the manufacturer in accordance with ISO standards or any other recognized national/international standards requirements. The validity of calibration certificates shall be verified by the Surveyor before witnessing tests.

1.9 Referenced Documents (2011)

The following documents form a part of the overall specification to the extent they are referenced in this ABS Rules document:

ANSI H35.1	Alloy and Temper Designation Systems for Aluminum
ASTM B928/928M	Standard Specification for High Magnesium Aluminum-Alloy sheet and plate for marine Service.
ASTM B221/221M	Standard Specification for Aluminum and Aluminum-Alloy Extruded Bars, Rods, Wire, Profiles, and Tubes
ASTM B247/247M	Standard Specification for Aluminum and Aluminum-Alloy Die Forgings, Hand Forgings, and Rolled Ring Forgings
ASTM B316/316M	Standard Specification for Aluminum and Aluminum – Alloy Rivet and Cold-Heading Wire and Rods
ASTM B209/209M	Standard Specification for Aluminum and Aluminum-Alloy Sheet and Plate
ASTM B26/26M	Standard Specification for Aluminum-Alloy Sand Castings
ASTM B108	Standard Specification for Aluminum-Alloy Permanent Castings
ASTM B918	Standard Practice for Heat Treatment of Wrought Aluminum Alloys
ASTM E34	Test methods for Chemical Analysis of Aluminum and Aluminum-Base Alloys
ASTM E1251	Test Method for optical Emission Spectrometric Analysis of Aluminum and Aluminum Alloys by Argon Atmosphere, point-to-plane, unipolar self-initiating Capacitor Discharge.
ASTM E8/8M	Standard Test methods for Tension Testing of Metallic Materials
ASTM B557/557M	Standard Test Methods of Tension Testing Wrought and Cast Aluminum – and Magnesium-Alloy Products
ASTM B565	Method for Shear Testing of Aluminum and Aluminum – Alloy Rivet and Cold-Heading Wire and Rods
AWS D1.2/D1.2M	Structural Welding Code – Aluminum
IACS UR W25	Materials and Welding – Aluminum Alloys for Hull Construction and Marine Structure
IACS UR W26	Materials and Welding – Requirements for Welding Consumables for Aluminum Alloys

3 Defects

All materials and weldments are to be generally free from linear, planar and volumetric physical defects such as embedded and through thickness flaws, laminations and injurious surface flaws or similar forms of defects that would be detrimental to the use of the materials and weldments in the intended applications. Welding or dressing for the purpose of remedying defects is not permitted unless and until sanctioned by the Surveyor. Discoloration characteristic of proper heat treatment schedules is not cause for rejection.

5 Manufacturer's Certificates

5.1 Form of Certificate (2014)

Four copies of the mill certificates or the shipping statements of all accepted plate and shape materials indicating the aluminum alloy and temper, the purchaser and order number, the construction project number (if available), the product quantity, dimension and weight, the chemical composition, the batch number (or identifying mark) and mechanical and corrosion test results as applicable, are to be furnished to the Surveyor for his approval; one is to be forwarded to the purchaser, three are to be retained for the use of ABS.

Before the mill certificates or shipping statements are distributed by the local ABS office, the manufacturer is to furnish the Surveyor with a certificate stating that the material has been sampled, tested and inspected in accordance with these Rules and that it has met the requirements. The following form of certificate will be accepted if printed on each mill sheet or shipping statement with the name of the firm and initialed by the authorized representative of the manufacturer:

“We hereby certify that the material described herein has been made to the applicable specifications of alloy _____; temper _____, and the required samples tested in accordance with the requirements of _____ (The American Bureau of Shipping Rules or state other specification) in the presence of a Surveyor from the American Bureau of Shipping with satisfactory results.”

At the request of manufacturers, consideration may be given to modifications to the form of certificate, provided it correspondingly indicates compliance with the requirements of these Rules to no less degree than indicated in the foregoing statement.

5.3 Other Certificates

Where an aluminum alloy ingot is not produced in the plant where it is rolled, extruded or forged, a certified report is to be supplied to the Surveyor stating the name of the manufacturer, the alloy, ingot or manufacturing and inspection lot identification numbers and certification that the alloy meets the required chemical composition limits.

5.5 Dual Certification

Dual certification of aluminum alloys is permitted only when alloy designations involved meet the specified chemical composition and specified minimum mechanical property requirements; provided they have the same ANSI temper designations in order to avoid any differences that may arise in welding and marine corrosion characteristics of the alloys with differing temper designations.

5.7 Electronic Certification System (2011)

An electronic certification system may be used to issue certified mill test reports, which may be electronically signed and stamped by an attending Surveyor, subject to the following conditions.

- All relevant information regarding the customer order, including the electronic certification request, is to be provided to the attending Surveyor by the manufacturer.
- Procedures are to be established to control handling and distribution of certified mill test reports among the manufacturer, ABS, and the purchaser.
- In order to implement the electronic certification system, the manufacturer is to be under mandatory ABS-QA program.

7 Identification Markings

7.1 Marine Grades

Aluminum alloys with ability to resist intergranular and exfoliation forms of corrosion when in direct contact with seawater or when used in marine environment conditions shall be treated as marine grades. Aluminum alloys with magnesium content greater than or equal to 3% are prone to these forms of corrosion and shall be tested, inspected and certified in accordance with ASTM B928 specification by the manufacturer. The acceptance criteria for corrosion tests (ASTM G66 and G67) are to follow ABS Rule requirements. The test results shall be reported on the mill certificates and are to be verified by the Surveyor. The alloy grade shall be suffixed with the letters “MG” while marking as indicated in 2-5-1/7.3.

7.3 Material Identification (2011)

All materials which have been sampled, tested and have successfully passed the requirements and have been approved by the Surveyor are to be clearly ink marked or stamped with the manufacturer's name or trademark and material identification on each finished sheet, plate, shape, bar, rod casing or forging to signify that the material has satisfactorily complied with the tests prescribed. The material identification is to include:

- i) The initials **AB**
- ii) The aluminum alloy designation according to the Aluminum Association
- iii) The temper designation according to the Aluminum Association
- iv) The manufacturers batch number
- v) The letter "MG" is to be added after the grade and temper designation only if the material has been corrosion tested as per requirements of Section 2-5-6 of these Rules and ASTM B928. Example:
AB/5083 H321 MG

7.5 Stenciled Material

In special cases, when approved, strapped or secured lifts or bundles of light sheet, plates, shapes, bars, rods or tubes of comparatively small size may be marked or stenciled on only the top piece or the marking may be shown on the tag attached to each lift or bundle.

PART

2

CHAPTER **5** **Materials for Hull Construction – Aluminum**

SECTION **2** **Standard Test Methods**

1 **General** (2011)

The latest issue of the following test methods or specifications or their equivalents are considered acceptable:

1.1 **Chemical Analysis**

The chemical analyses are to be carried out in accordance with ASTM E34 or ASTM E716 or ASTM E1251 or equivalent, as may be appropriate to a specific alloy under testing and consideration for certification. The sampling practice for chemical analyses is to be carried out as indicated in 2-5-3/3 and may follow a recognized standard to the extent as may be modified or stated in this document.

1.3 **Tension Testing**

Refer to 2-5-5 for requirements for test specimens.

Alternative Standards ASTM E 8/8M or ASTM B557/557M or equivalent may be used.

1.5 **Shear Testing**

Shear tests are to be carried out in accordance with ASTM B769 or ASTM B565 or equivalent.

1.7 **Hardness Testing***

Hardness tests, if applicable, are to be carried out in accordance with ASTM E18 or equivalent.

1.9 **Electrical Conductivity Testing***

Electrical Conductivity tests, if applicable, are to be carried out in accordance with ASTM E1004 or equivalent.

* *Note:* Hardness and Electrical Conductivity testing are reference only for evaluation of alloys and tempers of heat treatable aluminum products.

PART

2

CHAPTER **5 Materials for Hull Construction – Aluminum**

SECTION **3 Chemical Composition**

1 General

The chemical composition of each cast is to be determined by the aluminum manufacturer and is to conform to the applicable requirements of the alloys listed in 2-5-3/Table 1 or 2-5-3/Table 2 or such other requirements as may be specially approved.

3 Sampling

A control sample for chemical analysis is to be taken before starting to pour and one additional sample is to be taken during the pouring of each group of ingots poured simultaneously from the same source of molten metal. If not analyzed during pouring samples, it may be taken from semi-finished or finished products. When samples are taken from finished or semi-finished products, one sample is to represent each 1800 kg (4000 lb), or fraction thereof, of each alloy in an inspection lot. The manufacturer's declared analysis will be subject to occasional checks if required by the Surveyor.

Product analysis may be required where the final product chemistry is not well represented by the analysis from the cast.

When the aluminum alloys are not cast in the same works in which they are manufactured into semi-finished products, a certificate issued by the works is to be provided to the Surveyor which indicates the reference numbers and chemical composition of the heats.

5 Definition of an Inspection Lot

An inspection lot is defined as:

For non-heat treated tempers, an identifiable quantity of material of the same mill form, alloy, temper, section and size submitted for an inspection at one time before shipment. And for heat treated temper an identifiable quantity of material of the same mill form, alloy, temper, section and size traceable to a heat treated lot or lots and submitted for inspection at one time before shipment. Mill forms: sheet and plate, all material of the same thickness is considered to be of the same size.

TABLE 1
Chemical Composition Limits of Wrought Aluminum Alloys (2013)

Limits are in weight percent. Single value represents maximum limit, unless shown as a range or indicated as a minimum.

Alloy	Silicon	Iron	Copper	Manganese	Magnesium	Chromium	Zinc	Titanium	Others ⁽¹⁾		Aluminum
									Each	Total	
5052	0.25	0.40	0.10	0.10	2.2-2.8	0.15-0.35	0.10	–	0.05	0.15	Remainder
5059	0.45	0.50	0.25	0.60-1.2	5.0-6.0	0.25	0.40-0.90	0.20	0.05 ⁽⁵⁾	0.15 ⁽⁵⁾	Remainder
5083	0.40	0.40	0.10	0.40-1.0	4.0-4.9	0.05-0.25	0.25	0.15	0.05	0.15	Remainder
5086	0.40	0.50	0.10	0.20-0.7	3.5-4.5	0.05-0.25	0.25	0.15	0.05	0.15	Remainder
5383	0.25	0.25	0.20	0.70-1.0	4.0-5.2	0.25	0.4	0.15	0.05 ⁽⁴⁾	0.15 ⁽⁴⁾	Remainder
5454	0.25	0.40	0.10	0.50-1.0	2.4-3.0	0.05-0.20	0.25	0.20	0.05	0.15	Remainder
5456	0.25	0.40	0.10	0.50-1.0	4.7-5.5	0.05-0.20	0.25	0.20	0.05	0.15	Remainder
5754	0.40	0.40	0.10	0.50 ⁽²⁾	2.6-3.6	0.30 ⁽²⁾	0.20	0.15	0.05	0.15	Remainder
6005A	0.50-0.9	0.35	0.30	0.50 ⁽³⁾	0.4-0.7	0.30 ⁽³⁾	0.20	0.10	0.05	0.15	Remainder
6061	0.40-0.8	0.70	0.15-0.40	0.15	0.8-1.2	0.04-0.35	0.25	0.15	0.05	0.15	Remainder
6063	0.20-0.6	0.35	0.10	0.10	0.45-0.9	0.10	0.10	0.10	0.05	0.15	Remainder
6082	0.70-1.3	0.50	0.10	0.40-1.0	0.6-1.2	0.25	0.20	0.10	0.05	0.15	Remainder

Notes:

- (2011) The term ‘Others’ includes any other element(s) for which no specific limit is shown in the above table. Other element(s), if added intentionally or analyzed by the alloy producer or specified by the purchaser, are to be reported and not to exceed the limit as given in the ‘Others’ column.
- Mn + Cr : 0.10 – 0.60
- Mn + Cr : 0.12 – 0.50
- Zr: maximum 0.20. The total for other elements does not include Zirconium.
- Zr: 0.05-0.25. The total for other elements does not include Zirconium.

TABLE 2
Chemical Composition Limits of Cast Aluminum Alloys

AA Aluminum Association

Limits are in weight percent. Single value represents maximum limit, unless shown as a range or indicated as a minimum.

AA	Silicon	Iron	Copper	Manganese	Magnesium	Zinc	Titanium	Others		Aluminum
								Each	Total	
356.0	6.5–7.5	0.6 ⁽¹⁾	0.25	0.35 ⁽¹⁾	0.20–0.45	0.35	0.25	0.05	0.15	Remainder
A356.0	6.5–7.5	0.20	0.20	0.10	0.20–0.45	0.10	0.20	0.05	0.15	Remainder
357.0	6.5–7.5	0.15	0.05	0.03	0.45–0.6	0.05	0.20	0.05	0.15	Remainder

Note:

- If the iron content exceeds 0.45%, manganese content shall not be less than one half of the iron.

PART

2

CHAPTER **5 Materials for Hull Construction – Aluminum**

SECTION **4 Heat Treatment**

Alloys 6005A, 6061 and 6082 products are to be suitably **heat** treated to develop the mechanical properties specified in 2-5-5/Tables 2, 4, 5 and 6 for the various tempers. Alternative heat treatments will be specially considered.

- T4 Solution heat treated and then naturally aged.
- T451 For sheet and plate that are stress relieved by stretching after solution heat treatment.
- T4511 For extruded bars, rods or shapes that are stress relieved by stretching after solution heat treatment.
- T5 Cooled from an elevated temperature shaping process and then artificially aged. Usually associated with extruded products.
- T6 Solution heat treated and then artificially aged.
- T651 For sheet and plate that are stress relieved by stretching after solution heat treatment and then artificially aged.
- T6511 For extruded bars, rods or shapes that are stress relieved by stretching after solution heat treatment and then artificially aged.

PART

2

CHAPTER **5** **Materials for Hull Construction – Aluminum**

SECTION **5** **Tensile Properties**

1 **General**

Tensile properties are to conform to the applicable requirements of the alloys and tempers listed in 2-5-5/Tables 1 through 7. Mechanical properties for welded joints are lower for strain hardened or heat treated alloys. For as welded properties refer to Appendix 2-5-A1.

3 **Yield Strength**

The yield strength is defined as that determined at 0.2% offset.

5 **Standard Test Specimens**

5.1 **General (2011)**

Tension test specimens may be the full cross section of the material being tested or they may be machined as indicated for specific product forms. Test specimens in accordance with other recognized standards may be accepted subject to special approval.

5.3 **Full-Section Specimens**

Tension test specimens of the full cross section of the material may be used for wire, rod, bar, shapes and tubular products. It is permissible to reduce the section slightly throughout the section to insure fracture within the gauge marks.

5.5 **Machined Specimens**

Standard tension test specimens' requirements are indicated in 2-5-5/Figure 1.

The following designations are used:

d	=	diameter
a	=	thickness
b	=	width
L_0	=	original gauge length
L_c	=	parallel length
S_0	=	original cross sectional area
R	=	transition radius
D	=	external tube diameter
t	=	plate thickness

FIGURE 1
Standard Tension Test Specimen

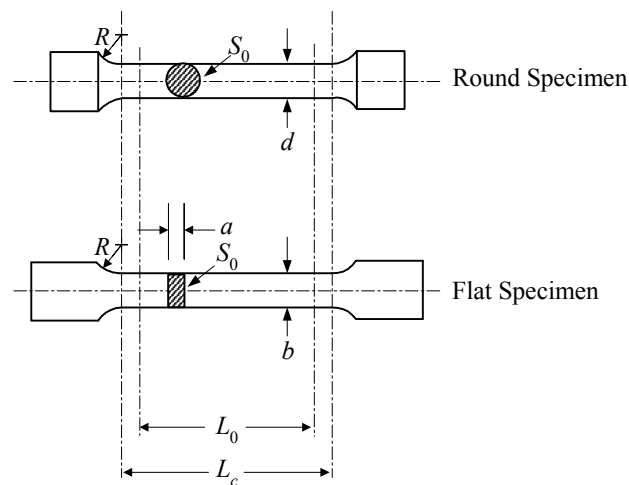

5.7 Dimensions

Proportional test specimens with a gauge length:

$$L_0 = 5.65 \sqrt{S_0}$$

can be used or preferably $5d$ can be used as the gauge length, L_0 should preferably be greater than 20 mm. The gauge length may be rounded off to the nearest 5 mm provided that the difference between this length and L_0 is less than 10% of L_0 .

Flat tensile test specimens shall be used for specified thicknesses up to and including 12.5 mm. The tensile test specimen shall be prepared so that both rolled surfaces are maintained. For thicknesses exceeding 12.5 mm, round tensile test specimens will be used. For thicknesses up to and including 40 mm, the longitudinal axis of the round tensile test specimen shall be located at a distance from the surface equal to half of the thickness. For thicknesses over 40 mm, the longitudinal axis of the round tensile test specimen shall be located at a distance from one of the surfaces equal to one quarter of the thickness.

5.7.1 Plates Strips and Sections

Flat specimens are usually to be used with dimensions as specified below

- *Proportional flat specimen*

$$\begin{aligned} a &= t \\ b &= 25 \text{ mm} \\ L_0 &= 5.65 \sqrt{S_0} \\ L_c &= L_0 + 2 \sqrt{S_0} \\ R &= 25 \text{ mm} \end{aligned}$$

- *Non-proportional flat specimen*

$$\begin{aligned} a &= t \\ b &= 25 \text{ mm} \\ L_0 &= 200 \text{ mm} \\ L_c &> 212.5 \text{ mm} \\ R &= 25 \text{ mm} \end{aligned}$$

When the capacity of the available testing machine is insufficient to allow the use of test specimen of full thickness, this may be reduced by machining one of the rolled surfaces.

Alternatively, for materials over 40 mm thick, proportional round test specimens with dimensions as specified below may be used.

- *Round specimen*

$$d \geq 10 \text{ mm to } 20 \text{ mm, preferably } 14 \text{ mm}$$

$$L_0 = 5d$$

$$L_c \geq L_0 + \frac{d}{2}$$

$$R = 10 \text{ mm (for materials with a specified elongation less than } 10\%, R \geq 1.5d)$$

The axes of the round test specimens are to be located at approximately one quarter of the thickness from one of the rolled surfaces.

5.7.2 Forgings and Castings

Proportional round test specimens with dimensions as specified above in 2-5-5/5.7.1 are usually to be used. For small size bars and similar products the test specimens may consist of a suitable length of bar or other product tested in the full cross-section.

5.9 Test Specimens Orientation and Location (2011)

The practice for orientation and location of tension test specimens is to be followed as per ASTM B557/557M or equivalent standard and to the extent as may be modified or stated in this document. The orientation and location of tension test specimens are to be indicated in the test report.

7 Retests

7.1 Defective Test specimen

If the percentage elongation of a tension test specimen is less than that specified, and if any part of the fracture is outside of the middle half of the gauge length or in a punched or scribed mark within the reduced section, another test specimen may be selected.

7.3 Failure to Meet Requirements (2012)

If any tension test specimen selected in accordance with 2-5-7/5, 2-5-8/5 or 2-5-9/5 fails to conform to the requirements, two additional specimens, for each specimen that failed, may be selected from the area that is adjacent to the area represented by the failure or failures. In the case of separately cast test specimens, for each specimen that failed, two additional cast specimens from the same batch may be selected for retest. If both of these additional tests are satisfactory, the remaining piece and/or the remaining material from the same batch may be accepted.

If one or both of the additional tests referred to above are unsatisfactory, the piece is to be rejected. If the rejected piece is from a batch, the remaining material from the same batch may be accepted provided that two of the remaining pieces in the batch are tested and conform to the requirements. If tension test specimens from either of these two pieces fail to conform to the requirements, the whole batch of material is to be rejected.

If the failure to conform to the requirements is the result of an inadequate thermal treatment, additional aging treatment, as applicable to the material, may be permitted at the discretion of the attending ABS Surveyor. However, no re-solution heat treatment of the alloys and tempers listed in this section is allowed.

In the event of material failing to comply with the test requirements the Classification brand stamp is to be unmistakably defaced by the manufacturer.

TABLE 1A
Mechanical Property Limits of Non-Heat-Treatable Sheet
and Plate Aluminum Alloys ^(2, 3) (2014)

Mechanical test specimens are taken as detailed in 2-5-5/5 or as specified in ASTM B 557/557M.

Alloy and Temper	Thickness ⁽¹⁾		Ultimate Tensile Strength N/mm ² (ksi)		Yield Strength 0.2% Offset N/mm ² (ksi)		Minimum Elongation Percent in		
	millimeters over - through	(inches)	minimum	maximum	minimum	maximum	50 mm	5d	2 in. /4d
5052-O	3.0–6.3	(0.118–0.249)	170 (25.0)	215 (31.0)	65 (9.5)		19	-	20
	6.3–80.0	(0.250–3.000)	170 (25.0)	215 (31.0)	65 (9.5)		18	16	18
5052-H32 ⁽⁴⁾	3.0–6.3	(0.118–0.249)	215 (31.0)	265 (38.0)	160 (23.0)		7	-	9
	6.3–12.5	(0.250–0.499)	215 (31.0)	265 (38.0)	160 (23.0)		11	-	11
	12.5–50.0	(0.500–2.000)	215 (31.0)	265 (38.0)	160 (23.0)		11	10	12
5052-H34 ⁽⁴⁾	3.0–6.3	(0.118–0.249)	235 (34.0)	285 (41.0)	180 (26.0)		6	-	7
	6.3–25.0	(0.250–1.000)	235 (34.0)	285 (41.0)	180 (26.0)		10	9	10
5052-H112	6.3–12.5	(0.250–0.499)	190 (28.0)		110 (16.0)		7	-	7
	12.5–40.0	(0.500–2.000)	170 (25.0)		65 (9.5)		-	10	12
	40.0–80.0	(2.001–3.000)	170 (25.0)		65 (9.5)		-	14	16
5059-O	3.0-20.0	(0.118-0.787)	330 (48.0)		160 (23.0)		24	24	24
	20.0-40.0	(0.788-1.575)	330 (48.0)		160 (23.0)		-	20	20
	40.0-50.0	(1.576-2.000)	300 (44.0)		145 (21.0)		-	17	17
5059-H111	3.0–20.0	(0.118–0.787)	330 (48.0)		160 (23.0)		24	24	24
	20.0–40.0	(0.788–1.575)	330 (48.0)		160 (23.0)		-	20	20
5083-O	3.0–50.0	(0.118–2.000)	275 (40.0)	350 (51.0)	125 (18.0)	200 (29.0)	16	14	16
5083-H111	3.0-50.0	(0.118-2.000)	275 (40.0)	350 (51.0)	125 (18.0)	200 (29.0)	16	14	16
5083-H112	3.0-40.0	(0.250-1.500)	275 (40.0)		125 (18.0)		12	10	12
	40.0-50.0	(1.501-2.000)	270 (39.0)		115 (17.0)		-	10	12
5086-O	3.0–6.3	(0.118–0.249)	240 (35.0)	305 (44.0)	95 (14.0)		18	-	18
	6.3–50.0	(0.250–2.000)	240 (35.0)	305 (44.0)	95 (14.0)		16	14	16
5086-H111	3.0-6.3	(0.118-0.249)	240 (35.0)	305 (44.0)	95 (14.0)		18	-	18
	6.3–50.0	(0.250–2.000)	240 (35.0)	305 (44.0)	95 (14.0)		16	14	16
5086-H112	3.0–12.5	(0.118–0.499)	250 (36.0)		125 (18.0)		8	-	8
	12.5–40.0	(0.500–1.000)	240 (35.0)		105 (16.0)		-	9	10
	40.0–80.0	(1.001–2.000)	235 (35.0)		95 (14.0)		-	12	14
5383-O	3.0–50	(0.118–2.000)	290 (42.0)		145 (21.0)		-	17	17
5383-H111	3.0–50	(0.118–2.000)	290 (42.0)		145 (21.0)		-	17	17
5454-O	3.0–6.3	(0.118–0.249)	215 (31.0)	285 (41.0)	85 (12.0)		16	-	18
	6.3–80.0	(0.250–3.000)	215 (31.0)	285 (41.0)	85 (12.0)		18	16	18
5454-H32 ^(4,5)	3.0–6.3	(0.118–0.249)	250 (36.0)	305 (44.0)	180 (26.0)		8	-	8
	6.3–50.0	(0.250–2.000)	250 (36.0)	305 (44.0)	180 (26.0)		12	10	12
5454-H34 ^(4,5)	3.0-4.0	(0.118-0.161)	270 (39.0)	325 (47.0)	200 (29.0)		6	-	6
	4.0-6.3	(0.162-0.249)	270 (39.0)	325 (47.0)	200 (29.0)		6	-	7
	6.3-25.0	(0.249-1.000)	270 (39.0)	325 (47.0)	200 (29.0)		10	9	10
5454-H112 ⁽⁵⁾	6.3–12.5	(0.250–0.499)	220 (32.0)		125 (18.0)		8	-	8
	12.5–40.0	(0.500–2.000)	215 (31.0)		85 (12.0)		-	9	11
	40.0–80.0	(2.001–3.000)	215 (31.0)		85 (12.0)		-	13	15
5456-O	3.0–6.3	(0.118–1.500)	290 (42.0)	365 (53.0)	130 (19.0)	205 (30.0)	16	-	16
	6.3–80.0	(1.501–3.000)	285 (41.0)	360 (52.0)	125 (18.0)	205 (30.0)	16	14	16
5456-H112	6.3–40.0	(0.250–1.500)	290 (42.0)		130 (19.0)		12	10	12
	40.1–80.0	(1.501–3.000)	285 (41.0)		125 (18.0)		-	10	12
5754-O	3.0–12.5	(0.118–0.138)	200 (29.0)	270 (39.0)	80 (12.0)		19	-	19
	12.6–50.0	(0.139–2.000)	190 (27.5)	240 (34.8)	80 (12.0)		18	17	18
5754-H111	3.0–12.5	(0.118–0.138)	200 (29.0)	270 (39.0)	80 (12.0)		19	-	19
	12.6–50.0	(0.139–2.000)	190 (27.5)	240 (34.8)	80 (12.0)		18	17	18

TABLE 1A (continued)
Mechanical Property Limits of Non-Heat-Treatable Sheet and Plate Aluminum Alloys ^(2, 3) (2014)

Notes:

- 1 Type of test specimen used depends on thickness of material: (See 2-5-5/5.)
- 2 (2011) Values applicable to longitudinal test specimens.
- 3 (2011) Use of the latest ASTM B209/209M specification may be approved upon application.
- 4 (2011) For the corresponding H2x temper, the maximum tensile strength and minimum yield strength do not apply.
- 5 (2013) 5454 is recommended for service applications where exposed to temperatures exceeding 65°C (150°F).
- 6 (2014) The mechanical properties for the O and H111 tempers are the same. However, they are separated to discourage dual certification as these tempers represent different processing.

TABLE 1B
Mechanical Property Limits of Non-Heat-Treatable Marine Grade Sheet and Plate Aluminum Alloys for Hull Construction ^(2, 3, 4) (2013)

Alloy and Temper	Thickness ⁽¹⁾		Ultimate Tensile Strength N/mm ² (ksi)		Yield Strength 0.2% Offset N/mm ² (ksi)		Minimum Elongation Percent in		
	millimeters over - through	(inches)	minimum	maximum	minimum	maximum	50 mm	5d	2 in. /4d
5059-H116	3.0–20.0	(0.118–0.787)	370 (54.0)		270 (39.0)		10	10	10
	20.0–40.0	(0.788–1.575)	360 (52.0)		260 (38.0)		-	10	10
5059-H321	3.0–20.0	(0.118–0.787)	370 (54.0)		270 (39.0)		10	10	10
	20.0–40.0	(0.788–1.575)	360 (52.0)		260 (38.0)		-	10	10
5083-H116	3.0–12.5	(0.118–0.499)	305 (44.0)		215 (31.0)		10	-	10
	12.5–40.0	(0.500–1.500)	305 (44.0)		215 (31.0)		-	10	12
	40.0–80.0	(1.501–3.000)	285 (41.0)		200 (29.0)		-	10	12
5083-H321	3.2–5.0	(0.125–0.187)	305 (44.0)	385 (56.0)	215 (31.0)		10	-	10
	5.0–12.5	(0.188–0.499)	305 (44.0)	385 (56.0)	215 (31.0)		12	-	12
	12.5–40.0	(0.500–1.500)	305 (44.0)	385 (56.0)	215 (31.0)		-	10	12
	40.0–80.0	(1.501–3.000)	285 (41.0)	385 (56.0)	200 (29.0)		-	10	12
5086-H116	3.0–6.3	(0.118–0.249)	275 (40.0)		195 (28.0)		8	-	8
	6.3–50.0	(0.250–2.000)	275 (40.0)		195 (28.0)		10	9	10
5086-H321	3.0–6.3	(0.118–0.249)	275 (40.0)	355 (52.0)	195 (28.0)		8	-	8
	6.3–8.0	(0.250–0.320)	275 (40.0)	355 (52.0)	195 (28.0)		9	-	9
5383-H116	3.0–50.0	(0.118–2.000)	330 (48.0)		230 (33.0)		10	10	10
5383-H321	3.0–50.0	(0.118–2.000)	330 (48.0)		230 (33.0)		10	10	10
5456-H116	3.0–12.5	(0.118–0.499)	315 (46.0)		230 (33.0)		10	-	10
	12.5–30.0	(0.500–1.250)	315 (46.0)		230 (33.0)		-	10	12
	30.0–40.0	(1.251–1.500)	305 (44.0)		215 (31.0)		-	10	12
	40.0–80.0	(1.501–3.000)	285 (41.0)		200 (29.0)		-	10	12
5456-H321	3.0–4.0	0.118–0.187	330 (48.0)	405 (59.0)	235 (34.0)		10	-	10
	4.0–12.5	0.188–0.499	315 (46.0)	405 (59.0)	230 (33.0)	315 (46.0)	12	10	12
	12.5–40.0	0.500–1.500	305 (44.0)	385 (56.0)	215 (31.0)	305 (44.0)	-	10	12
	40.0–80.0	(1.501–3.000)	285 (41.0)	370 (54.0)	200 (29.0)	295 (43.0)	-	10	12

Notes:

- 1 Type of test specimen used depends on thickness of material: (See 2-5-5/5.)
- 2 (2011) Values applicable to longitudinal test specimens.
- 3 (2011) Marine Grade sheet and plate as shown in 2-5-5/Table 1B are to be capable of passing an appropriate test for resistance to exfoliation and intergranular corrosion. Refer to Section 2-5-6 for full details of corrosion test requirements.
- 4 (2013) Use of the latest ASTM B 928/928M specification may be approved upon application.

TABLE 2
Long Transverse Mechanical Property Limits of Heat-Treatable Sheet and Plate Aluminum Alloys ^(2, 6) (2011)

Mechanical test specimens are taken as detailed in 2-5-5/5 or as specified in ASTM B 557/557M.

Alloy and Temper	Type	Thickness ⁽¹⁾		Minimum Tensile Strength <i>N/mm²</i> (<i>ksi</i>)	Minimum Yield Strength 0.2% Offset <i>N/mm²</i> (<i>ksi</i>)	Minimum Elongation Percent in		
		millimeters over - through	(inches)			50 mm	5d	2 in. /4d
6061-T4	Sheet	3.0–6.3	(0.118–0.249)	205 (30.0)	110 (16.0)	16	-	16
6061-T451 ^(4,5)	Plate	6.3–25.0	(0.250–1.000)	205 (30.0)	110 (16.0)	18	16	18
		25.0–80.0	(1.001–3.000)	205 (30.0)	110 (16.0)	-	14	16
6061-T6 and -T62 ⁽³⁾	Sheet	3.0–6.3	(0.118–0.249)	290 (42.0)	240 (35.0)	10	-	10
6061-T62 ⁽³⁾ and -T651 ^(4,5)	Plate	6.3–12.5	(0.250–0.499)	290 (42.0)	240 (35.0)	10	-	10
		12.5–25.0	(0.500–1.000)	290 (42.0)	240 (35.0)	-	8	9
		25.0–50.0	(1.001–2.000)	290 (42.0)	240 (35.0)	-	7	8
		50.0–80.0	(2.001–3.000)	290 (42.0)	240 (35.0)	-	5	6

Notes:

- 1 Type of test specimen used depends on thickness of material; (See 2-5-5/5).
- 2 (2011) Values applicable to long transverse test specimens.
- 3 (2011) These properties apply to samples of material, which are solution heat treated or solution and precipitation treated from O or F temper by the producer to determine that the material will respond to proper heat treatment. Properties attained by the user, however, may be lower than those listed if the material has been formed or otherwise cold or hot worked, particularly in the annealed temper, prior to solution heat treatment.
- 4 For stress-relieved tempers, characteristics and properties other than those specified may differ somewhat from the corresponding characteristics and properties of material in the basic temper.
- 5 Upon artificial aging, T451 temper material is to be capable of developing the mechanical properties applicable to the T651 temper.
- 6 (2011) Use of the latest ASTM B209/209M specification may be approved upon application.

TABLE 3
Longitudinal Mechanical Property Limits of Non-Heat-Treatable Aluminum Alloys
for Extruded Bars, Rods, Shapes, and Tubes ^(2, 3) (2011)

Mechanical test specimens are taken as detailed in 2-5-5/5 or as specified in ASTM B 557/557M.

Alloy and Temper	Maximum Diameter or Thickness ⁽¹⁾		Maximum Area		Ultimate Tensile Strength N/mm ² (ksi)		Minimum Yield Strength 0.2% Offset	Minimum Elongation Percent in		
	mm	(in.)	mm ²	(in ²)	minimum	maximum	N/mm ² (ksi)	50 mm	5d	2 in./4d
5059-H112	50	(2.0)	---	---	330 (48.0)	---	200 (29.0)	-	10	10
5083-O ⁽⁴⁾	130.0	(5.0)	20000	(32)	270 (39.0)	350 (51.0)	110 (16.0)	14	12	14
5083-H111 ⁽⁴⁾	130.0	(5.0)	20000	(32)	275 (40.0)		165 (24.0)	12	10	12
5083-H112 ⁽⁴⁾	130.0	(5.0)	20000	(32)	270 (39.0)		110 (16.0)	12	10	12
5086-O ⁽⁴⁾	130.0	(5.0)	20000	(32)	240 (35.0)	315 (46.0)	95 (14.0)	14	12	14
5086-H111 ⁽⁴⁾	130.0	(5.0)	20000	(32)	250 (36.0)		145 (21.0)	12	10	12
5086-H112 ⁽⁴⁾	130.0	(5.0)	20000	(32)	240 (35.0)		95 (14.0)	12	10	12
5383-O	50	(2.0)	---	---	290 (42.0)	---	145 (21.0)	17	17	17
5383-H111	50	(2.0)	---	---	290 (42.0)		145 (21.0)	17	17	17
5383-H112	50	(2.0)	---	---	310 (45.0)		190 (27.5)	-	13	13
5456-O ⁽⁴⁾	130.0	(5.0)	20000	(32)	285 (41.0)	365 (53.0)	130 (19.0)	14	12	14
5456-H111 ⁽⁴⁾	130.0	(5.0)	20000	(32)	290 (42.0)		180 (26.0)	12	10	12
5456-H112 ⁽⁴⁾	130.0	(5.0)	20000	(32)	285 (41.0)		130 (19.0)	12	10	12

Notes:

- 1 Type of test specimen used depends on thickness of material; (see 2-5-5/5.)
- 2 (2011) Values applicable to longitudinal test specimens.
- 3 (2011) Use of the latest ASTM B221/221M specification may be approved upon application.
- 4 (2011) Properties not applicable to extruded tube over 70 mm (2.999 inch) wall thickness.

TABLE 4
Mechanical Property Limits of Heat-Treatable Aluminum Alloys
for Extruded Products ^(2, 6) (2011)

Mechanical test specimens are taken as detailed in 2-5-5/5 as specified in ASTM B 557/557M.

Alloy and Temper	Diameter or Thickness ⁽¹⁾		Area	Ultimate Tensile Strength N/mm ² (ksi)	Yield Strength 0.2% Offset N/mm ² (ksi)	Minimum Elongation Percent in		
	millimeters over - through	(inches)	mm ² /in ²	minimum	minimum	50 mm	5d	2 in./4d
6005A-T5	3.0–6.3 6.3–50.0	(0.118–0.249) (0.250–2.000)	All	260 (38.0) 260 (38.0)	215 (31.0) 215 (31.0)	7 9	- 8	7 9
6005A-T6	3.0–10.0 10.0–50.0	(0.118–0.400) (0.401–2.000)	All	260 (38.0) 260 (38.0)	215 (31.0) 200 (29.0)	8 8	- 6	8 8
6005A-T61	3.0–6.3 6.4–25.0	(0.118–0.249) (0.250–0.999)	All	260 (38.0) 260 (38.0)	240 (35.0) 240 (35.0)	8 10	- 9	8 10
6061-T4/T4511 ^(4,5)	All	All	All	180 (26.0)	110 (16.0)	16	14	16
6061-T6 ^(4,5) , -T62 ⁽³⁾ and -T6511 ^(4,5)	3.0–6.3 6.3 and over	(0.118–0.249) (0.250 and over)	All	260 (38.0) 260 (38.0)	240 (35.0) 240 (35.0)	8 10	- 9	8 10
6063-T6, -T62 ⁽³⁾	3.0–3.2 3.2–25.0	(0.118–0.124) (0.125–1.000)	All	205 (30.0) 205 (30.0)	170 (25.0) 170 (25.0)	8 10	- 9	8 10
6082-T5	3.0–50.0	(0.118–2.000)	All	270 (39.0)	230 (33.0)	8	6	8
6082-T6, -T6511	3.0–5.0 5.0–50.0 50.0–150.0	(0.118–0.199) (0.200–2.000) (2.001–6.000)	All	290 (42.0) 310 (45.0) 310 (45.0)	250 (36.0) 260 (38.0) 260 (38.0)	6 10 -	- 8 8	6 10 8

TABLE 4 (continued)
Mechanical Property Limits of Heat-Treatable Aluminum Alloys
for Extruded Products ^(2, 6) (2011)

Notes:

- 1 Type of test specimen used depends on thickness of material; (see 2-5-5/5.)
- 2 (2011) Values applicable to longitudinal test specimens.
- 3 (2011) These properties apply to samples of material, which are solution heat treated or solution and precipitation treated from O or F temper by the producer to determine that the material will respond to proper heat treatment. Properties attained by the user, however, may be lower than those listed if the material has been formed or otherwise cold or hot worked, particularly in the annealed temper, prior to solution heat treatment.
- 4 For stress-relieved tempers, characteristics and properties other than those specified may differ somewhat from the corresponding characteristics and properties of material in the basic temper.
- 5 Upon artificial aging, T4 and T4511 temper material are to be capable of developing the mechanical properties applicable to the T6 and T6511 tempers, respectively.
- 6 (2011) Use of the latest ASTM B221/221M specification may be approved upon application.

TABLE 5
Mechanical Property Limits for Die Forgings ⁽³⁾ (2011)

Alloy and Temper	Thickness	Specimen Axis Parallel to Direction of Grain Flow					Specimen Axis Not Parallel to Direction of Grain Flow				
		Minimum Ultimate Tensile Strength	Minimum Yield Strength 0.2% Offset	Minimum Elongation Percent in ⁽⁴⁾			Minimum Ultimate Tensile Strength	Minimum Yield Strength 0.2% Offset	Minimum Elongation Percent in ⁽⁴⁾		
				50 mm	5d	2 in. /4d			50 mm	5d	2 in. /4d
5083-H111	to 100 (4)	290 (42.0)	150 (22.0)	14	12	14	270 (39.0)	140 (20.0)	12	10	12
5083-H112	to 100 (4)	275 (40.0)	125 (18.0)	16	14	16	270 (39.0)	110 (16.0)	14	12	14
5456-H112 ⁽¹⁾	to 100 (4)	303 (44.0)	140 (20.0)	16	16	16					
6061-T6	to 100 (4)	260 (38.0)	240 (35.0)	7 ⁽²⁾	6 ⁽²⁾	7 ⁽²⁾	260 (38.0)	240 (35.0)	5	4	5

Notes:

- 1 (2011) Alloy 5456 is not covered in ASTM B247/247M, but use of such forgings meeting these requirements may be considered.
- 2 (2010) When sample is selected from a separately-forged test coupon, an elongation minimum of 10% applies.
- 3 (2011) Use of the latest ASTM B247/247M Specification may be approved upon application.
- 4 (2011) Elongation values apply to test specimens taken from an actual forging or its prolongation.

TABLE 6
Mechanical Property Limits for Hand Forgings ^(2, 3) (2011)

Alloy and Temper	Thickness	Axis of Test Specimen	Minimum Ultimate Tensile Strength	Minimum Yield Strength 0.2% Offset	Minimum Elongation Percent in	
	mm (in.)		N/mm ² (ksi)	N/mm ² (ksi)	5d	4d
5083-H111	to 100 (4)	Longitudinal	290 (42.0)	150 (22.0)	12	14
		Long transverse	270 (39.0)	140 (20.0)	10	12
5083-H112	to 100 (4)	Longitudinal	275 (40.0)	125 (18.0)	14	16
		Long transverse	270 (39.0)	110 (16.0)	12	14
5456-H112 ⁽¹⁾	to 75 (3)	Longitudinal	305 (44.0)	140 (20.0)	16	16
		Long transverse	290 (42.0)	125 (18.0)	14	14
6061-T6/-T652	to 100 (4)	Longitudinal	260 (38.0)	240 (35.0)	9	10
		Long transverse	260 (38.0)	240 (35.0)	7	8
		Short transverse ⁽²⁾	255 (37.0)	230 (33.0)	4	5
6061-T6/-T652	over 100 (4) to 200 (8)	Longitudinal	255 (37.0)	235 (34.0)	7	8
		Long transverse	255 (37.0)	235 (34.0)	5	6
		Short transverse	240 (35.0)	220 (32.0)	3	4

Notes:

- 1 (2011) Alloy 5456 is not covered in ASTM B247/247M, but use of such forgings meeting these requirements may be considered.
- 2 Requirement applicable to thicknesses of 50 mm (2 in.) and greater.
- 3 (2011) Use of the latest ASTM B247/247M Specification may be approved upon application.

TABLE 7
Mechanical Property Limits for Aluminum Alloy Castings (2011)

AA Aluminum Association

Alloy	Temper	Casting	Minimum Ultimate Tensile Strength	Minimum Yield Strength 0.20% Offset	Minimum Elongation in 50 mm (2 in.)
			N/mm ² (ksi)	N/mm ² (ksi)	percent
356.0	T6	Sand	205 (30.0)	140 (20.0)	3
		Permanent mold	228 (33.3)	152 (22.0)	3
A356.0	T6 T61	Sand	235 (34.0)	165 (24.0)	3.5
			245 (35.0)	180 (26.0)	1.0
A356.0	T61	Separately cast coupons Permanent mold	262 (38.0)	179 (26.0)	5
	T61		Integral coupons	230 (33.3)	179 (26.0)
357.0	T6	Permanent mold	310 (45.0)		3

TABLE 8
Aluminum Alloy Equivalents

AA Aluminum Association
 BS British Standard
 ASTM American Society for Testing and Material
 UNI Unificazione Nazionale Italiana
 CSA Canadian Standards Association
 JIS Japanese Industrial Standard
 NF Normes Francaises
 ISO International Organization for Standardization

The equivalents are approximate based on the best available information. The actual specification or standard should be consulted for full information.

<i>U.S. ASTM, AA</i>	<i>Canada CSA</i>	<i>France NF</i>	<i>U.K. BS</i>	<i>Italy UNI</i>	<i>Japan JIS</i>	<i>ISO</i>
5052	GR20		2L, 55, 2L, 56, L80, L81	PA1Mg2.5	A2-1	A1Mg2.5Mn
5083	GM41, E54S*		N8		A2-7	A1Mg4.5Mn
5086		AG4MC				A1Mg4
5454	GM31N, 55330*					A1Mg3Mn
5456			N61			
6061	GS11N		H20		A2-4	A1Mg1SiCu

Note:

* Commercial designations.

PART

2

CHAPTER **5 Materials for Hull Construction – Aluminum**

SECTION **6 Corrosion Testing**

1 General (2014)

Rolled 5xxx-alloys delivered in the H111, H112, H116 and H321 tempers (as listed in 2-5-5/Table 1B) intended for use in marine hull construction or in marine applications where frequent direct contact with seawater is expected are to be corrosion tested with respect to exfoliation and intergranular corrosion resistance as per requirements of this Section and ASTM B 928/928M. These alloys should not be used for service which provides prolonged exposure (continuous or discontinuous) to temperatures exceeding 65°C (150°F) because of the risk of sensitization and the resulting susceptibility to intergranular corrosion and stress corrosion cracking.

The alloy grades of the 6000 series should not be used in direct contact with seawater unless protected by anodes and/or paint system.

3 Reference Photomicrograph (2014)

The manufacturers shall establish the relationship between microstructure and resistance to corrosion when the above alloys are approved. A reference photomicrograph taken at 500× [using 40% phosphoric acid etch for 3 minutes at 35°C (50°F)], under the conditions specified in ASTM B928, Section 9.4.1, shall be established for each of the alloy-tempers and thickness ranges relevant. The reference photographs shall be taken from samples which have exhibited no evidence of exfoliation corrosion and a pitting rating of PB or better, when subjected to the test described in ASTM G66 (ASSET). The samples shall also have exhibited resistance to intergranular corrosion at a mass loss no greater than 15 mg/cm², when subjected to the test described in ASTM G67 (NAMLT). Upon satisfactory establishment of the relationship between microstructure and resistance to corrosion, the master photomicrographs and the results of the corrosion tests are to be approved by ABS. Production practices shall not be changed after approval of the reference micrographs.

Other recognized test methods may also be accepted at ABS's discretion.

5 Batch Microstructural Analysis and Acceptance (2014)

For batch acceptance of 5xxx-alloys in the H111, H112, H116 and H321 tempers, metallographic examination of one sample selected from mid width at one end of a coil or random sheet or plate may be carried out, provided that surveillance testing as stated in 2-5-6/7 is performed. The microstructure of the sample is to be compared to the reference photomicrograph [taken at 500× after 3 minutes etch in phosphoric acid at 35°C (50°F)] of acceptable material in the presence of the Surveyor. A longitudinal section perpendicular to the rolled surface shall be prepared for metallographic examination, under the conditions specified in ASTM B928, Section 9.6.1. If the microstructure shows evidence of continuous grain boundary network of aluminum-magnesium precipitate in excess of the reference photomicrographs of acceptable material, the batch is either to be rejected or tested for exfoliation-corrosion resistance and intergranular corrosion resistance subject to the agreement of the Surveyor. The corrosion tests are to be in accordance with ASTM G66 and G67 or equivalent standards. Acceptance criteria are that the sample shall exhibit no evidence of exfoliation corrosion and a pitting rating of PB or better when test subjected to ASTM G66 ASSET test, and the sample shall exhibit resistance to intergranular corrosion at a mass loss no greater than 15 mg/cm² (0.0002 lbs/in²) when subjected to ASTM G67 NAMLT test. If the results from testing satisfy the acceptance criteria stated in 2-5-6/3 the batch is accepted, else it is to be rejected.

As an alternative to metallographic examination, each batch may be tested for exfoliation corrosion resistance and intergranular corrosion resistance, in accordance with ASTM G66 and G67 **under the conditions specified in ASTM B928**, or equivalent standards, and accepted if the results satisfy the acceptance criteria stated in 2-5-6/3.

7 Surveillance of Corrosion Testing (2011)

The manufacturer shall perform, each quarter or after any process change, at least one test for exfoliation corrosion resistance and one test for intergranular corrosion resistance, in accordance with ASTM G66 and G67 or equivalent standards for each approved alloy grade. The manufacturer shall maintain records of all surveillance test results and make them available to the Surveyor for product certification.

PART

2

CHAPTER 5 Materials for Hull Construction – Aluminum

SECTION 7 Sheet, Plate and Rolled Products

1 Scope

The following requirements cover non-heat-treatable and heat-treatable aluminum alloys for sheet plate, and rolled products intended to be used in hull construction.

3 Selection of Tension Test Specimen (2011)

For rolled products, test samples are taken at one-third of the width from the longitudinal edge. Tension test specimens for non-heat-treatable rolled products are to be taken in the longitudinal direction. For heat-treatable rolled products, generally tests in the long transverse direction are required. If the width is insufficient to obtain long transverse test specimens, and when specified, tests in the longitudinal direction may be permitted. Short transverse testing, when specified, is only applicable to plate having a specified thickness of 40 mm (1.500 in.) or greater. The standard rectangular tension test specimen shown in 2-5-5/Figure 1 is to be used for sheet and plate less than 12.5 mm (0.5 in.) in thickness. For plate 12.5 mm (0.5 in.) and greater in thickness, the round tension test specimen shown in 2-5-5/Figure 1 is to be used. The tension test specimen is to be taken midway between the two plate surfaces for plate in thicknesses of 12.5 mm (0.5 in.) up to 40 mm (1.57 in.). For plate over 40 mm (1.57 in.) in thickness, the specimen shall be taken midway between the center and surface of the plate.

After removal of test samples, each test specimen is to be marked in order that its original identity, location and orientation is maintained.

5 Number of Tension Tests

Tension test specimens are to be selected as follows.

5.1 Sheet

For sheet under 6.3 mm (0.25 in.) in thickness, one tensile test specimen is to be taken from one random sheet representative of 900 kg (2000 pounds) or fraction thereof in each batch.

5.3 Plate and Rolled Products

For plate and rolled products 6.3 mm (0.25 in.) and over in thicknesses, one tensile test specimen is to be taken from each batch of the product. If the weight of one batch exceeds 2000 kg (4410 lb), or fraction thereof, one extra tensile test specimen is to be taken from every 2000 kg (4410 lb) or fraction thereof, in each batch.

For single plates or coils weighing more than 2000 kg (4410 lb) each, only one tensile test specimen per plate or coil is to be taken.

5.5 Definition of a Batch

The term batch applies to products if they are all:

- The same alloy grade from the same cast;
- The same product form and similar dimensions (for plates, the same thickness);
- Manufactured by the same process, and;
- Submitted simultaneously to the same temper condition.

7 Surface Finish (2014)

The material is to be free from injurious defects and have a workmanlike finish. Surface imperfections may be removed by smooth grinding or machining as long as the thickness of the material remains within the tolerances given in 2-5-7/11. It is to be surface inspected at the mill by the surveyors only when specifically requested and so ordered by the purchaser.

9 Nondestructive Examination (NDE)

In general NDE of material is not required for acceptance purposes.

However, the manufacturer is expected to employ suitable methods of NDE for maintaining compliance with quality standards.

11 Dimensions and Tolerance

It is the Manufacturer’s responsibility to check dimensions and to comply with the following tolerance requirements.

Under-thickness for rolled products are given in 2-5-7/Table 1. Dimensional tolerances other than under-thickness tolerance are to comply with a recognized national or international standard.

TABLE 1
Under-thickness Tolerance for Rolled Products

Nominal Thickness (<i>t</i>), mm	Thickness Tolerances for Nominal Width (<i>w</i>), mm		
	$w \leq 1500$	$1500 < w \leq 2000$	$2000 < w \leq 3500$
$3.0 \leq t < 4.0$	0.10	0.15	0.15
$4.0 \leq t < 8.0$	0.20	0.20	0.25
$8.0 \leq t < 12.0$	0.25	0.25	0.25
$12.0 \leq t < 20.0$	0.35	0.40	0.50
$20.0 \leq t < 30.0$	0.45	0.50	0.65

PART

2

CHAPTER 5 Materials for Hull Construction – Aluminum

SECTION 8 Extrusions

1 Scope

The following requirements cover extruded non-heat-treatable and heat-treatable aluminum alloy products intended to be used in hull construction.

3 Selection of Specimens

For extruded products tension test specimens are to be taken in the range $\frac{1}{3}$ to $\frac{1}{2}$ of the distance from the longitudinal edge to the centre of the thickest part.

Tension test specimens are to be taken in the longitudinal direction and are to be of the full section of the material where practicable. Otherwise, the specimens shown in 2-5-5/Figure 1 are to be used. For material 40 mm (1.57 in.) and less in diameter or thickness, the specimen is to be taken from the center of the section. For material greater than 40 mm (1.57 in.) in thickness or diameter the specimen is to be located midway between the center and an edge.

After removal of test samples, each test specimen is to be marked in order that its original identity, location and orientation are maintained.

5 Number of Tests

5.1 Tension Tests

For the products with a nominal weight of less than 1 kg/m (0.7 lb/ft), one tensile test specimen is to be taken from each 1000 kg, (2205 lb) or fraction thereof, in each batch. For nominal weights between 1 and 5 kg/m (0.7 and 3.5 lb/ft), one tensile test specimen is to be taken from each 2000 kg (4410 lb) or fraction hereof, in each batch. If the nominal weight exceeds 5 kg/m (3.5 lb/ft), one tensile test specimen is to be taken for each 3000 kg (6615 lb) of the product or fraction thereof, in each batch.

5.3 Drift Expansion Tests

The Manufacturer is to demonstrate by macrosection tests or drift expansion tests of closed profiles performed on each batch of closed profiles that there is no lack of fusion at the press welds.

5.3.1 Drift Expansion Tests (2008)

- Every fifth profile shall be sampled after final heat treatment.
- Batches of five profiles or less shall be sampled one profile.
- Profiles with lengths exceeding 6 m shall be sampled every profile in the start of the production.
- The number of tests may be reduced to every fifth profile if the results from the first 3-5 profiles are found acceptable.
- Each profile sampled will have two samples cut from the front and back end of the production profile.
- The test specimens are to be cut with the ends perpendicular to the axis of the profile.

- The edges of the end may be rounded by filing.
- The length of the specimen is to be in accordance with 2-5-8/Figure 1 or recognized standard such as ISO 8493.
- Testing is to be carried out at ambient temperature and is to consist of expanding the end of the profile by means of a hardened conical steel mandrel having an included angle of at least 60°.
- The sample is considered to be unacceptable if the sample fails with a clean split along the weld line, which confirms lack of fusion.
- The entire batch of closed profiles (press welded) being tested is to be rejected if the sampled profile fails during drift expansion test. However, each profile in the rejected batch may be tested individually and accepted if it passes the test.

FIGURE 1
Drift Expansion Test

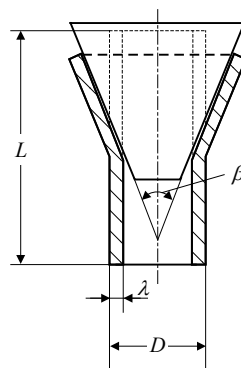

Notes

- 1 L equal to twice the external diameter D of the tube if the angle of the drift is 30°, and L equal to $1.5D$ if the angle of the drift is 45° or 60°.
- 2 The test piece may be shorter provided that after testing the remaining cylindrical portion is not less than $0.5D$.
- 3 The rate of penetration of the mandrel shall not exceed 50 mm/min.

5.5 Definition of a Batch

The term batch applies to products if they are all:

- The same alloy grade from the same cast;
- The same product form and similar dimensions (for plates, the same thickness);
- Manufactured by the same process, and;
- Submitted simultaneously to the same temper condition.

7 Surface Finish (2014)

The material is to be free from injurious defects and have a workmanlike finish. **Surface imperfections may be removed by smooth grinding or machining as long as the thickness of the material remains within the tolerances given in 2-5-8/11.** It is to be surface inspected at the mill only when specifically requested and so ordered by the purchaser.

9 Nondestructive Examination (NDE)

In general NDE of material is not required for acceptance purposes.

However, the manufacturer is expected to employ suitable methods of NDE for maintaining compliance with quality standards.

11 Dimensions and Tolerance

It is the Manufacturer's responsibility to check dimensions and to comply with the following tolerance requirements:

Under-thickness tolerances for extruded products are to be in accordance with recognized national or international standards.

Dimensional tolerances other than under-thickness tolerance are to comply with recognized national or international standards.

PART

2

CHAPTER **5 Materials for Hull Construction – Aluminum**

SECTION **9 Forgings**

1 Scope (2013)

The following requirements cover non-heat-treatable and heat-treatable aluminum alloy die and hand forgings intended to be used in hull construction. The material covered is in substantial agreement with ASTM B247. Forgings differing in chemical composition, mechanical properties or heat treatment will be specially considered.

Forgings are to be made by a manufacturer approved by ABS.

ABS approval is valid for 5 years subject to annual verification and/or endorsement by the attending Surveyor. The Surveyor is permitted at any time to monitor important aspects of forging production, including but not limited to die preparation and die maintenance, forging temperatures, forging reduction or upset, heat treatment and inspection.

3 Selection of Specimens

3.1 Location of Specimens

Tension test specimens are to be taken from prolongations having a sectional area not less than that of the body of the forging. Tension test specimens are normally taken parallel to the direction in which the metal is most drawn out (longitudinal) but may be taken transversely. Specimens taken in the longitudinal direction are to be taken from as near to the center of the cross-section of the forging as is practicable. The midpoint of the axes of transverse specimens are to be near to the center of the cross section of the forging.

3.3 Small Forgings

In the case of forgings weighing less than 114 kg (250 lb) each, where the foregoing procedures are impracticable, a special forging may be made for the purpose of obtaining test specimens, provided the Surveyor is satisfied that these test specimens are representative of the forgings submitted for testing. In such cases, the special forging should be subjected to the same amount of working and reduction as the forging represented and, if applicable, be heat treated with those forgings. Alternatively, test specimens may be taken from one of the forgings in the lot.

3.5 Test Specimens

The tension test specimen shown in 2-5-5/Figure 1 is to be used.

5 Number of Tests

5.1 Large Forgings

In the case of forgings weighing over 2700 kg (6000 lb) each, one tension test specimen is to be taken from each end of the forging.

5.3 Smaller Forgings

In the case of forgings weighing less than 2700 kg (6000 lb) each, except as noted in 2-5-9/5.5 and 2-5-9/5.7, one tension test specimen is to be taken from each forging.

5.5 Small Forgings

In the case of forgings weighing less than 114 kg (250 lb) each, one tension test specimen may be taken from one forging as representative of 900 kg (2000 lb), provided the forgings are of similar size, of one alloy and temper, are made from the same lot of stock and, if applicable, heat treated in the same furnace charge.

5.7 Special Situations

In the case of a number of pieces cut from a single forging, individual tests need not necessarily be made for each piece, but forgings may be tested in accordance with whichever of the foregoing procedures is applicable to the primary forging involved.

7 Inspection

The forgings are to be inspected by the Surveyor after final heat treatment, where applicable, to insure that the forgings are free from injurious defects.

9 Nondestructive Examination (NDE)

The manufacturer is to carry out suitable methods of NDE for maintaining compliance with quality standards.

11 Dimensions and Tolerance

It is the Manufacturer's responsibility to check dimensions and to comply with tolerance requirements.

CHAPTER 5 Materials for Hull Construction – Aluminum**SECTION 10 Castings****1 Scope (2013)**

The following requirements cover aluminum alloy castings for use in hull construction. The material covered is in substantial agreement with alloys in accordance with ASTM Designations B26 and B108 (Aluminum Association alloys 356.0, A356.0 and AA357.0)-. Except in cases specifically approved otherwise, all aluminum castings are to be furnished in the heat treated condition. Castings differing in chemical composition, mechanical properties or heat treatment from those covered herein will be specially considered.

Castings are to be made by a manufacturer approved by ABS.

ABS approval is valid for 5 years subject to annual verification and/or endorsement by the attending Surveyor. The Surveyor is permitted at any time to monitor important aspects of casting production, including but not limited to mold preparation and chaplet positioning; pouring times and temperatures; mold breakout; repairs; heat treatment and inspection.

3 Selection of Specimens**3.1 Large Castings**

Tensile specimens are to be taken from integral test bars. Integral test bars are not to be detached until the heat treatment of the castings has been completed nor until the coupons have been stamped by the Surveyor for identification.

3.3 Small Castings

In the case of castings weighing less than 450 kg (1000 lb) each, test coupons may be cast separately, provided they are poured from the same source of molten metal as the castings represented. When separate coupons are used, the Surveyor is to be furnished an affidavit by the manufacturer stating that the coupons were poured from the same source of molten metal as the castings represented and that they were heat treated with the castings.

3.5 Test Specimens

The tension test specimen shown in 2-5-5/Figure 1 is to be used.

5 Number of Tests

At least one tension test is to be made representative of the same source of molten metal and in each heat-treatment charge.

7 Inspection

The castings are to be inspected by the Surveyor after final heat treatment and thorough cleaning to insure that the castings are free from injurious defects, such as cracks, laminations, or embedded porosity. The final machined casting is to be examined to avoid the presence of surface defects.

9 Welded Repair of Defects

Defects in noncritical areas may, with the Surveyor's approval, be repaired by welding using an approved procedure. The welding is to be done before the final heat-treatment.

11 Nondestructive Examination (NDE)

The manufacturer is to carry out suitable methods of NDE for maintaining compliance with quality standards.

13 Dimensions and Tolerance

It is the Manufacturer's responsibility to check dimensions and to comply with tolerance requirements.

PART

2

CHAPTER **5** **Materials for Hull Construction – Aluminum**

SECTION **11** **Rivets**

1 **General**

Non-heat-treatable and heat-treatable aluminum alloy cold heading rod and wire for use in manufacturing rivets should be in agreement with a specification equivalent to ASTM Designation B316. Material differing from ASTM B316 in chemical composition, mechanical properties or heat-treatment may be specially considered.

PART

2

CHAPTER 5 Materials for Hull Construction – Aluminum

APPENDIX 1 Aluminum Welding in Hull Construction

1 General

1.1 Hull Welding

Welding in aluminum hull construction is to comply with the requirements of this Appendix, unless specially approved otherwise. It is recommended that appropriate permanent welded markings be applied to the side shell of welded craft to indicate the location of bulkheads for reference. In all instances, welding procedures and filler metals are to be applied which will produce sound welds that have strength in accordance with 2-5-A1/Table 2; the chemical compositions of the filler metals are to be generally in accordance with 2-5-A1/Table 3. The selection of filler metals for welding various aluminum alloys is to be in accordance with 2-5-A1/Tables 4 and 5.

1.3 Plans and Specifications

The plans submitted are to clearly indicate the extent to which welding is proposed to be used. The welding process, filler metal and joint design are to be shown on the detail drawings or in separate specifications submitted for approval, which are to distinguish between manual, semi-automatic and automatic welding. The shipbuilders are to prepare and file with the Surveyor a planned procedure to be followed in the erection and welding of the important structural members.

1.5 Workmanship and Supervision

It shall be the responsibility of the contractor to insure that personnel, procedures and NDT equipment used for fabrication and inspection comply with these requirements. However, the Surveyor is to satisfy himself that all welders and welding operators to be employed in the construction of craft to be classed are properly qualified and are experienced in the type of work proposed and in the proper use of the welding processes and procedures to be followed. The Surveyor is to be satisfied with the employment of a sufficient number of skilled supervisors to ensure a thorough supervision and control of all welding operations.

1.7 Welding Procedures

Procedures for the welding of all joints are to be established in writing for each welding test, process, type of electrode, edge preparation, welding technique and position proposed. Details of proposed welding procedures and sequences are required to be submitted for review. Procedure qualifications previously prepared and approved by ABS may be submitted for consideration for the current designs, if applicable.

3 Preparation for Welding

3.1 Edge Preparation and Fitting

The edge preparation is to be accurate and uniform and the parts to be welded are to be fitted in accordance with the approved welding detail. Joint edges may be prepared by mechanical means, such as saws, millers and routers and by plasma arc cutting. Thermal cutting methods may be employed, provided it can be demonstrated to the satisfaction of the Surveyor that their use does not have deleterious effects on the base material or completed weld.

All means for correcting improper fitting are to be to the satisfaction of the Surveyor. Where excessive root openings of butt weld connections are encountered, weld build up of the plate edges may be allowed, at the discretion of the Surveyor, before welding the plates together. Unless specially approved otherwise, such build up of each plate edge, where permitted, is not to exceed $0.5t$ or 12.5 mm ($1/2$ in.) whichever is less, where t is the thickness of the thinner plate being welded. Where sections to be joined differ in thickness and have an offset on either side of more than 3 mm ($1/8$ in.), a transition having a length not less than three times the offset is to be provided. The transition may be formed by tapering the thicker member or by specifying a weld joint design which will provide the required transition.

3.3 Alignment

Means are to be provided for maintaining the parts to be welded in correct position and alignment during the welding operation. In general, strong backs or other appliances used for this purpose are to be arranged so as to allow for expansion and contraction during production welding. The removal of such items is to be carried out to the satisfaction of the Surveyor.

3.3.1 Plate Alignment Tolerances

3.3.1(a) *Butt Welds*. Where plates are tacked in preparation for butt welding, the deviation of alignment of surfaces at the weld joint shall meet the requirements specified below:

Plate Thickness	Maximum Allowable Deviation
Less than 9.5 mm (0.375 in.)	1.5 mm (0.0625 in.)
9.5 mm (0.375 in.) to 19 mm (0.75 in.)	3 mm (0.125 in.)
19 mm (0.75 in.) to 38 mm (1.5 in.)	5 mm (0.1875 in.)
38 mm (1.5 in.)	6 mm (0.25 in.)

3.3.1(b) *Fillet Welds*. When the opening between elements of a fillet welded joint exceeds 1.5 mm ($1/16$ in.) but not more than 5 mm ($3/16$ in.) as a nominal condition along the joint, the fillet size shall be increased by an amount equal to the excess of the opening above 1.5 mm ($1/16$ inch). Where the gap between members exceeds 5 mm ($3/16$ in.) as a nominal condition along the joint fillet, methods outlined below shall be used. Fillet welds shall be extended around the ends of members to form closed loops, where possible.

i) *Buttering and Buildup*. Buttering or buildup by welding on the weld joint surface to correct oversized root opening or errors in joint preparation is allowed, provided such buildup of each joint edge shall not exceed t or 12 mm (0.5 in.), whichever is less, where t is the thickness of the thinner member being welded. Where one side of a joint may not be accessible, the total buttering or buildup (that is $2t$ or 25 mm (1 in.), whichever is less) may be deposited on one member. Temporary backing may be used to assist in the buttering or buildup. When root openings cannot be corrected within this limitation, repair shall be made using patches, make-up plates and so forth, in accordance with ii) and iii) below

Buttering or buildup may be employed for fairing or for other corrections over or adjacent to welds, provided the above restrictions are not exceeded. This buildup shall be considered part of the involved weld.

ii) *Make-up Plates*. Make-up plates welded into primary structure shall have a minimum width of three (3) inches and shall have full penetration, 100 percent efficient butt welds.

iii) *Access and Closure Plates*. Boundaries of access and closure plates shall be located between principal boat framing or bulkheads, and shall be at least 75 mm (3 in.) from any of these members. When variance from this 75 mm (3 in.) minimum is required by special circumstances, such variances shall be subject to approval by the Surveyor. The boundaries of access and closure plates should land on existing butts or seams, wherever practical. See 2-5-A1/Figures 1A and 1B below.

Corners of access or closure plates shall have a minimum radius of 75 mm (3 in.), except when a boundary lands on an existing hull longitudinal or transverse butt joint. In the latter instance, the corners shall intersect the weld at an angle of 90 ± 15 degrees (see 2-5-A1/Figures 1A and 1B below). Closure plate weld joints shall be full penetration 100 percent efficient butt welds.

FIGURE 1A
Inserts and Patches in Plating

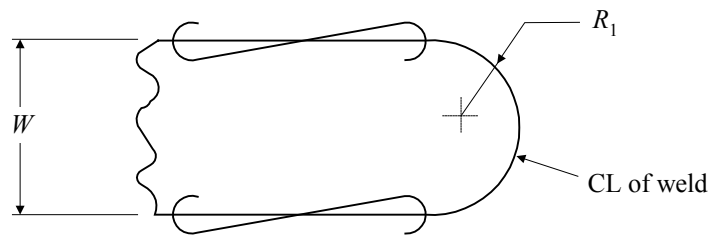

WHEN $W = 3''$ min.
 Then $R_1 = W/2$

FIGURE 1B
Inserts and Patches in Plating

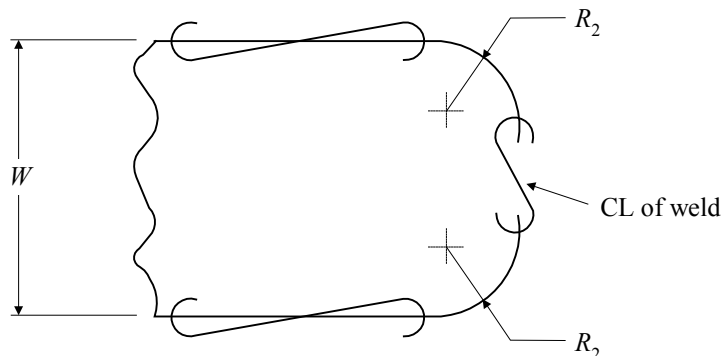

WHEN $W = 6''$ min.
 Then $R_2 = 3''$ or $2t$, whichever is larger

3.5 Cleanliness (2012)

Suitable solvents or mechanical means are to be used to remove oil, grease, indelible markings, and all other contaminants from the vicinity of all joints prior to welding. -Oxide films that can not be removed by the specific welding process, including any water stains (hydrated alumina oxide) are to be removed from the groove surfaces that are to be welded, including joint and faying surfaces as well as adjacent surfaces within one inch of the weld. Removal may be by mechanical means, such as a power driven, clean stainless steel wire brush, sanding with a 36-100 grit aluminum oxide sanding disk or by approved chemical means. Welding shall take place within eight hours of removal of oxide films except in way of faying surfaces of fillet welds. Interpass cleaning to remove slag, soot, overlap conditions, spatter, etc is required. Degreasers are not to be used when the joint is such that the degreaser can collect in crevices such as faying surfaces between plate and backing bars or in way of lapped connections. Fusion welding is not to be performed on anodically-treated aluminum, except when the surface oxide is removed from the joint areas to be welded.

3.7 Tack Welds

Tack welds shall be made with the same type of electrode as the final weld and should be deposited to facilitate incorporation into the final weld. Tack welds of poor quality or workmanship shall be removed.

3.9 Stud Welding

The attachment of pins, hangers, studs and other related items by stud welding may be approved at the discretion of the Surveyor. At the Surveyor's discretion, trial stud welds should be tested to demonstrate that stud welds and base material in way of stud welds are sufficiently sound for the intended application, prior to actual production work. The use of stud welding for structural attachments is subject to special approval and may require special procedure tests appropriate to each application.

3.11 Temporary Back-up Plates and Tapes

A temporary back-up plate may be applied to the opposite side of the joint during welding to assist in reducing distortion and to decrease heat concentration. Anodized "hard" aluminum back-up plates are recommended for this purpose, although clean stainless steel or rust-free mild steel plates may also be used. Back-up plates when used are to be free of contaminants and oxides which would interfere with welding. Welding is to be controlled so as not to allow arcing of the aluminum filler metal to the temporary back-up plate. Any accidental arcing to the back-up plate is to be corrected by removal of all contaminated weld or base metal. Approval of procedures involving the use of backing tapes may be considered, provided it is demonstrated to the Surveyor's satisfaction that their use results in satisfactory welding and that plate distortion is not excessive.

3.13 Run-on and Run-off Tabs

When used, run-on and run-off tabs are to be designed to minimize the possibility of high-stress concentrations and cracking of the base metal and weld metal.

3.15 Forming

Cold forming of 5000 series aluminum alloys is to be conducted at temperatures below 52°C (125°F), except for the 5454 alloy, where the maximum temperature may be 149°C (300°F). See 2-5-A1/Table 1 below for minimum cold-forming radii. When the extent of cold forming is such that base plate properties are changed beyond acceptable limits, appropriate reheat or stress relief treatments are to be used to reestablish acceptable properties. Hot forming of 5000 series aluminum alloys is generally conducted at temperatures between 260°C and 425°C (500°F and 800°F). Hot or cold forming is not to be performed in structures of any aluminum alloy unless supporting data is presented to the Surveyor's satisfaction indicating that significant material property changes will not result. Appropriate temperature control methods are to be used in all hot forming and stress relieving operations. In hot forming or stress relieving, exposure of the 5000 series alloys to the 65°C (150°F) to 200°C (400°F) temperature range is to be minimized by the use of appropriate cooling techniques. Typically, 6000 series aluminum is not to be formed. For 6000 series aluminum to be considered for forming, supporting technical data is to be submitted for review and approval prior to forming.

TABLE 1
Minimum Cold-forming Radii for Aluminum Alloys ^(1, 2, 3)

<i>Alloy and temper</i>	<i>3 mm (0.125 in.)</i>	<i>5 mm (0.1875 in.)</i>	<i>6 mm (0.25 in.)</i>	<i>9.5 mm (0.375 in.)</i>	<i>12 mm (0.50 in.)</i>
5083-0	1t	1, 2t	1, 2t	2t	2t
H113	1, 1½t	1, 2t	1, 2t	1½, 2t	2, 3t
H323	1½, 3t	1½, 3½t	2, 4t	-----	-----
H343	1½, 3t	2, 4t	2½, 4½t	-----	-----
5052-0	1t	1t	1t	1, 1½t	1, 2t
H32	1, 1½t	1, 1½t	1, 1½t	1, 2t	1½, 2½t
H34	1½, 2½t	1½, 2½t	2, 3t	2, 3t	2½, 3½t
H36	1½, 3t	2, 4t	2, 4t	2½, 5t	3½, 5½t
H38	2, 4t	3, 5t	4, 6t	4, 7t	5, 8t
5086-0	1t	1t	1t	1, 1½t	1, 2t
H32,H116,H117	1, 2t	1, 2t	1½, 2½t	2, 2½t	2½, 3t
H34	1½, 2½t	2, 3t	2, 3t	2½, 3½t	3, 4t
H36	2, 3½t	2½, 4t	3, 4½t	3, 5t	3½, 5½t
H112			1, 2t	1, 2t	1½, 2½t
5456-0	1t	1, 2t	1, 2t	2t	2t
H116,H117	2, 3t	2, 3t	2, 3t	3, 4t	3, 4t
H323	1½, 3t	1½, 3½t	2, 4t	-----	-----
H343	1½, 3t	2, 4t	2½, 4½t	-----	-----

Notes:

- 1 Where two radii are shown, the larger radius is applicable when the bend is parallel to the direction of rolling.
- 2 These bending radii are applicable to aluminum alloys which are free of visible oxide coating.
- 3 The radii shall be the mandrel radii or inside radii.

5 Production Welding

5.1 Environment

Proper precautions are to be taken to insure that all welding is done under conditions where the welding site is protected against deleterious effects of moisture, wind and severe cold. Paint or oil mist and other contaminants which tend to cause weld porosity are to be excluded from the vicinity where welding is in progress.

5.3 Preheat

Preheating is not generally required for aluminum alloys. The use of preheat may be desirable when welding materials of thick cross section, materials subject to high restraint, and when welding is performed under high humidity conditions or when the temperature of the aluminum alloy is below 0°C (32°F). When preheating is used, appropriate production controls are to be used to maintain the specified temperatures, in accordance with accepted procedures and to the satisfaction of the Surveyor. Preheating temperatures which sensitize an alloy to corrosion are to be avoided. For the 5000 series alloys, it is generally recommended to avoid prolonged exposure to the 65°C to 200°C (150°F to 400°F) temperature range. Preheat and interpass temperatures shall be verified by temperature sticks, small contact thermometer, pyrometer, etc. a minimum of 25 mm (1 in.) away from the weld area.

5.5 Postheating

Weldments of work hardenable 5000 series aluminum alloys are not to be postweld heat treated unless the procedures have been specially approved. Where use of a heat-treatable alloy has been approved, any postweld heat treatment proposed is to be as established in procedure qualification tests. Post weld heat treatment is not required on 5000 series aluminum materials, stainless steels, copper alloys or nickel alloys.

5.7 Accessibility

Assembly and welding is to be arranged to provide sufficient accessibility to the joint by the welder, the welding equipment and for inspection.

5.9 Sequence

Welding is to be planned to progress symmetrically so that shrinkage on both sides of the structure will be equalized. The ends of frames and stiffeners are to be left unattached to the plating at the sub-assembly stage for a distance of about 300 mm (12 in.) until connecting welds are made in the intersecting systems of plating, framing and stiffeners at the erection stage. Welds are not to be carried across an unwelded joint or beyond an unwelded joint which terminates at the joint being welded unless especially approved.

5.11 Back Gouging

Chipping, routing, milling, grinding or other suitable methods are to be employed at the root or underside of the weld to obtain sound metal before applying subsequent beads for all full-penetration welds.

5.13 Fairing and Flame Shrinking

Shrink welds may be used, but fairing by heating or flame shrinking to correct distortion or defective workmanship in fabrication of main strength members within the midships portion of the craft and other plating which may be subject to high stresses is not generally recommended. If intended to be used, it is to be carried out only with the expressed approval of the Surveyor. For the 5000 series alloys, it is generally recommended that heating and cooling through the sensitizing range of 65°C-200°C (150°F-400°F) is to be as rapid as practicable.

5.15 Inspection of Welds

5.15.1 Visual Inspection

Visual inspection during construction is to consist of inspecting the surface appearance of welds for the existence of flaws or defects, as stated below. The inspection zone includes the weld face and 12 mm (0.5 in.) of adjacent base metal. The surface of the welds is to be regular and uniform with proper contour, a minimum amount of reinforcement and reasonably free from undercut and overlap, slag, paint and weld splatter.

5.15.1(a) Appearance. Welds shall be free of cracks, incomplete fusion and burn-through. Visible arc-strikes on welds and the adjacent base metal are not allowed and shall not exceed 1 mm ($1/32$ in.) in depth after removal. Weld spatter greater in diameter than 1 mm ($1/32$ in.) is not acceptable. Gouge marks, nicks and other fabrication scars in the weld inspection zone shall not exceed the requirements for undercut. Weld surfaces shall be free of slag to the extent that there is no interference with visual or other required nondestructive test. Crater pits are considered acceptable, provided the area contains no cracks, and the root concavity and convexity limits are not exceeded and the minimum weld thickness requirements are met.

5.15.1(b) Melt-through. Melt-through and repaired burn-through areas are acceptable, provided the areas do not contain cracks, crevices, excessive oxidation or globules, and provided that the root convexity and concavity limits are not exceeded.

5.15.1(c) Suckback. Suckback is unacceptable in a weld or base metal when it occurs as a sharp notch or where the depth reduces the weld thickness below the minimum base metal thickness.

5.15.1(d) Undercut. The minimum undercut shall be 1 mm ($1/32$ in.) or 10% of the adjacent base metal thickness, whichever is less. For base metal thickness 12 mm (0.5 in.) and greater, undercut from 1 mm ($1/32$ in.) to 1.5 mm ($1/16$ in.) is allowed if the accumulated length of undercut does not exceed 15% of the joint length or 300 mm (12 in.), whichever is less.

5.15.1(e) *Welded Joint Offset.* The maximum offset for all welded joints shall be as follows:

<i>Base Metal Thickness</i>	<i>Maximum Offset</i>
1/4 in. and less	25% of joint thickness
Over 1/4 in. to 3/4 in.	25% of joint thickness, but not to exceed 1/8 in.
Over 3/4 in. to 1 1/2 in.	3/16 in.
Over 1 1/2 in.	12 1/2% of joint thickness, but not to exceed 1/4 in.

For misalignments that exceed the table above and less than $0.50t$, the structure may be fixed by using deep penetration welds. For misalignments that exceed $0.50t$ and are less than $1.0t$, the structure may be fixed by aligning flat bar doubling strips. Misalignments greater than $1.0t$ are to be corrected by realignment of the structure. See 2-5-A1/Figure 2.

FIGURE 2
Repairs of Misalignments

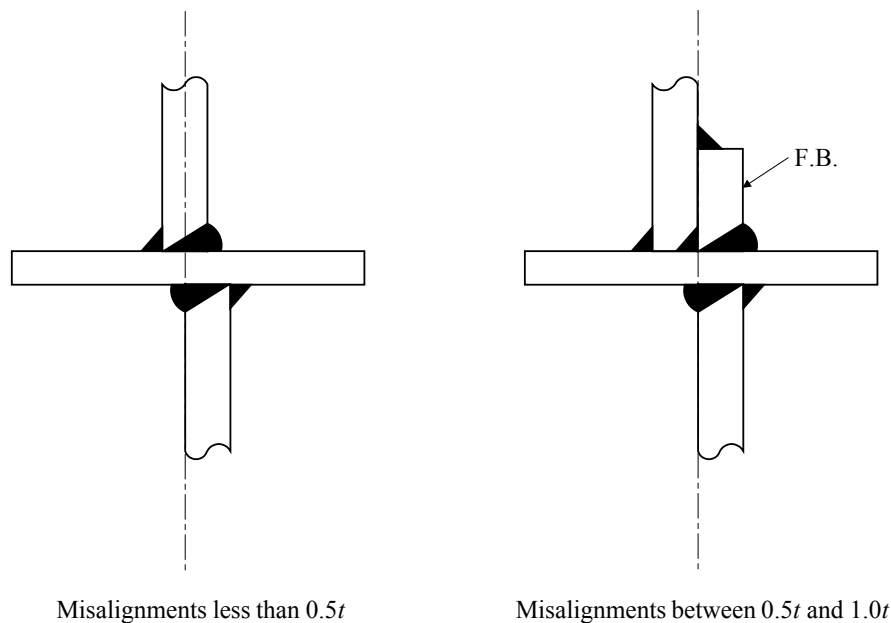

5.15.2 Dye Penetrant

Dye penetrant inspection is to be used when investigating the outer surface of welds or may be considered for use as a check of intermediate weld passes, such as root passes and also to check back-chipped, ground or gouged joints prior to depositing subsequent passes. Any dye penetrant used is to be thoroughly removed from the area before re-welding. Dye penetrant is not to be used where complete removal of the dye penetrant materials cannot be assured.

5.15.2(a) *Type of Dye Penetrant.* Penetrant materials consist of solvent-removable, visible dye penetrant with associated penetrant remover (solvent) and nonaqueous wet developer.

5.15.2(b) *Surface Preparation.* Surfaces to be inspected shall be free from scale, slag and adhering or imbedded sand or other extraneous materials. With the exception of undercuts which are within allowances, the contour of welds shall blend smoothly and gradually into the base metal. Weld surface irregularities shall be removed to the extent that they will not interfere with interpretation of the test results. The final liquid penetrant inspection shall be performed in the final surface condition, as specified herein.

Peening, shot, sand, grit and vapor blasting shall not be performed on surfaces before liquid penetrant inspection.

Surfaces for which a specific finish is required shall be given this surface finish prior to the final liquid penetrant inspection.

5.15.2(c) Test Procedure Requirements. All surfaces being tested shall be thoroughly cleaned of extraneous material. If a nonvolatile liquid is used for cleaning, the surface shall be heated or dried with hot air to assure complete removal of the cleaner. As a final cleaning operation, each surface shall be dipped, sprayed, wiped or brushed with an acceptable solvent and thoroughly dried by removing the excess with a clean dry cloth or absorbent paper, and allowing the remainder to evaporate for a minimum of five minutes. Prior to liquid penetrant inspection, the surface to be tested and any adjacent area within one (1) inch of the surface to be tested shall be dry and free of any dirt, grease, lint, scale and salts, coatings or other extraneous matter that would obscure surface openings or otherwise interfere with the test.

Maximum penetration into extremely small openings requires that the penetrant and the test surface be maintained at the temperature recommended by the penetrant manufacturer, but in no case shall be less than 50°F. The temperature of the penetrant and the test surface shall not exceed 100°F. Due to the flammable nature of liquid penetrant inspection materials, the use of an open flame for heating purposes shall be prohibited. Special conditions requiring deviation from the above requirement requires approval of the Surveyor.

The surface to be tested shall be thoroughly and uniformly coated with penetrant by flooding, brushing, immersion or spraying. Unless otherwise recommended by the manufacturer and approved by the Surveyor, dwelling time for the penetrant shall be not less than 15 minutes and no greater than 20.

The excess penetrant shall be removed from all surfaces as follows:

- i)* As much excess penetrant as possible shall be removed by wiping the surface thoroughly with a clean dry cloth or absorbent paper.
- ii)* The remaining excess penetrant shall be removed by wiping the surface with a clean cloth or absorbent paper dampened with a penetrant remover specified by the penetrant material manufacturer.

Flushing of the surface with any liquid following application of the penetrant and prior to developing is prohibited.

The drying of the test surface after the removal of the excess penetrant shall be accomplished only by normal evaporation, or by blotting with absorbent paper or clean, lint-free cloth. Forced air circulation in excess of normal ventilation in the inspection area shall not be used. Unless otherwise specified by the penetrant manufacturer, the time for surface drying after removal of excess penetrant and prior to application of the developer shall be limited to a maximum of ten (10) minutes.

A nonaqueous wet developer specified by the penetrant manufacturer shall be used. Immediately prior to application, the developing liquid shall be kept agitated in order to prevent settling of solid particles dispersed in the liquid. The developer shall be uniformly applied in a thin coating to the test surfaces by spraying. Pools of wet developer in cavities on the inspection surface is not permitted since these pools will dry to an excessively heavy coating in such areas resulting in the masking of indications. Inspection shall be made a minimum of seven (7) minutes and not later than 30 minutes after the developer has dried.

When the inspection is concluded, the penetrant materials shall be removed as soon as possible by means of wiping, water-wetted clean cloth or solvents, as described above, and with applicable cleaning procedures.

5.15.3 Radiographic or Ultrasonic Inspection

Radiographic or ultrasonic inspection or both may be used when the overall soundness of the weld cross section is to be evaluated. Finished welding is to be sound and thoroughly fused throughout its cross section and to the base material. Production welds are to be crack free. Other discontinuities, such as incomplete fusion or incomplete penetration, slag and porosity, are only to be present to the degree permitted by the pertinent inspection standard. The procedures and standards for radiographic and ultrasonic inspection is to be in accordance with ABS's separately issued publication, *Guide for Nondestructive Inspection of Hull Welds*, or other approved acceptance standards.

5.15.4 Weld Plugs or Samples

The practice of taking weld plugs or samples by machining or cutting from the welded structure is not recommended and is to be considered only in the absence of other suitable inspection methods and is to be subject to the special approval of the Surveyor. When such weld plugs or samples are removed from the welded structure, the holes or cavities formed are to be properly prepared and welded, using a suitable welding procedure approved by the Surveyor and as established for the original joint

5.17 Workmanship Requirements

The workmanship requirements include the visual acceptance criteria stated in 2-5-A1/5.15.1 above plus the following structural fairness requirements provided below. In addition, welded attachments shall be removed to a minimum of 1.5 mm (0.0625 in.) away from the permanent member to which they are attached by chipping, sawing or cutting, followed by grinding or sanding to restore the plate surface.

5.17.1 Structural Fairness for Plating

Unfairness (deviation from the design molded line) of welded plating shall not exceed the tolerances shown on 2-5-A1/Figures 3 and 4. Permissible unfairness should result in a generally fair curve across the panel, except that an additional deviation of 3 mm (1.8 in.) from the fair curve is permitted in way of welded butts and seams. Sharp knuckling or bend in way of stiffeners shall be avoided. A procedure for measuring fairness and taking corrective actions shall be developed and be available for review by the surveyor.

If aid is necessary in determining the acceptability of the fairness of welded structure, a measurement of the unfairness of plating may be made in the area of interest. In such cases, the measurement shall be made across the minor dimension of the panel. The tolerances specified on 2-5-A1/Figures 3 and 4 are plus or minus the dimensions from a fair line.

For stiffener spacings greater or less than those shown on 2-5-A1/Figures 3 and 4, the curves shall be extrapolated proportionately.

5.17.2 Structural Fairness for Framing and Stiffeners

Frame, beam and stiffener bows in primary strength structure or structure subject to dynamic loading shall be corrected when it varies plus or minus from the designated or molded line in excess of the following:

$$T = C \left(\frac{\ell}{dw} \right) \text{ mm (in.)}$$

where

T = tolerance in mm (in.)

C = 530 (0.25)

ℓ = span of member between the fixed ends at the support structure in m (ft)

dw = depth of the stiffening member measured from the underside of the flange in mm (in.)

5.17.3 Underwater Exterior Surfaces

In general, weld surfaces shall not extend greater than 1.5 mm (0.0625 in.) above the plate surface.

5.19 Quality Control

To maintain quality control, sample welds may be required to be made by welders and operators during each three (3) month period, at the discretion of the Surveyor and at the location of production welding, using the same equipment, material and filler metal as intended for production. The sample welds are to be examined for acceptable workmanship and may be required to be sectioned, etched and examined for weld soundness. When necessary, measures are to be taken to correct unacceptable workmanship.

5.21 Repair Welding

Unsatisfactory welding, as determined by visual inspection, nondestructive test methods, or leakage under hydrostatic tests, is to be corrected by the removal of the defective weld or adjacent material or both and corrected by rewelding, using a suitable repair welding procedure consistent with the material being welded. The repair procedures shall be available for the welder. Multiple repairs (weld cycles) to 5000 series aluminum alloys in the same general area are allowed. Removal by mechanical means of minor surface defects such as arc strikes, scratches or shallow gouges may be permitted at the discretion of the attending Surveyor. Repaired welds must meet the inspection requirements for the original weld.

7 Butt Welds

7.1 Joint Design

Hull plating up to 5.0 mm ($3/16$ in.) in thickness may be square-butt welded without beveling the abutting plate edges. Plates exceeding 5.0 mm ($3/16$ in.) may be prepared for welding by similarly beveling the edges of both plates from one or both sides to form a single-Vee or double-Vee butt joint with an included angle from 60 degrees to 90 degrees. For single-Vee butt joints in material 5.0 mm ($3/16$ in.) and thicker, the root face or land may be up to 3.0 mm ($1/8$ in.) in depth. Root faces or lands below 1.5 mm ($1/16$ in.) are not generally recommended. For double-Vee butt joints in material 8.0 mm ($5/16$ in.) and thicker, the gap may vary from 0 to 5.0 mm ($3/16$ in.). Joints of other designs and root openings, such as the square butt joints in heavy thicknesses used with automated procedures will be subject to special consideration. In general, use of double-Vee in lieu of single-Vee joints and the narrowest root gap practicable is recommended to minimize distortion.

Butt-type permanent backing strap joints welded from one side shall not be used. For both single-Vee and double-Vee joints, the weld metal at the root on the reverse side of a weld made without permanent backing is to be removed to sound metal by an approved method before applying subsequent weld passes. See 2-5-A1/5.11. Welded butt joints made against removable backing and on which the root is inspected in accordance with these requirements shall be considered the equivalent of a joint welded from both sides.

9 Fillet Welds

See Section 3-2-13 of the *ABS Rules for Building and Classing High Speed Naval Craft* or Section 30.9 of the *ABS Rules for Building and Classing Aluminum Vessels*.

11 Filler Metals

11.1 General

Filler metals are to be of a type suitable to produce sound welds that have strength, ductility and corrosion-resistant properties comparable to the materials being welded. Appropriate precautions are to be used to prevent any critical property change of filler wire quality during storage and handling. A list of recommended filler metals for different alloys is given in 2-5-A1/Tables 4 and 5.

11.3 Approval Basis

Filler metals will be approved and listed, subject to tests conducted at the manufacturer's plant. Upon satisfactory completion of tests, a certificate will be issued for general approval indicating the grade or classification to which the filler metal was tested and the relevant characteristics of the filler metal. Test assemblies are to be prepared in the presence of the Surveyor and all tests are to be attended by and carried out to the satisfaction of the Surveyor. Procedure and testing is to comply with either of the following standards.

- i) Filler metals will be considered for approval based upon tests conducted to standards established by the American Welding Society or other recognized agency.
- ii) Special approvals to manufacturer's specifications.

13 Approval of Welding Procedures

13.1 Approved Filler Metals

Approval of aluminum alloy filler metals used on ABS-classed weldments will depend on the specific application and alloys for which the filler metal is intended. Procedure tests may be required as a general condition of approval or at the discretion of the attending Surveyor to determine the shipyard's or fabricator's capability in the application of the proposed filler metal to the base material. The extent of such tests may vary depending upon the intended application, but generally would follow those tests outlined in 2-5-A1/13.7, and are to be carried out under production conditions.

13.3 Surveyor's Acceptance

The Surveyor may, at his discretion, accept a filler metal, welding procedure, or both, in a shipyard or fabricator's plant where it is established to his satisfaction that they have been adequately used for similar work under similar conditions.

13.5 New Procedures and Methods

Weld tests, as outlined in 2-5-A1/13.7 and 2-5-A1/13.9 and 2-5-A1/Figure 5 to 2-5-A1/Figure 17, using procedures and materials similar to those intended for production welding and carried out under production conditions, may be required to be prepared by each shipyard or fabricator when new or unusual methods, base metals or filler metals are proposed.

All tests are to be made in the presence of the Surveyor and carried out to the Surveyor's satisfaction.

13.7 Tests

Tests Nos. 1 and 2 are to be carried out for procedures involving butt welds. Test No. 3 is to be carried out for procedures involving fillet welds. Unless otherwise specified, the number of specimens is to be as indicated. The minimum test results required are stated with the figures:

- *Test No. 1 – Reduced Section Tension Test* (with reinforcement removed) (2-5-A1/Figure 7 or 2-5-A1/Figure 8). Two specimens made in each position involved. The test specimens are to meet or exceed the ultimate tensile strength shown in 2-5-A1/Table 1.
- *Test No. 2 – Guided Bend Test* (2-5-A1/Figure 9 or 2-5-A1/Figure 10). For material 12.5 mm (0.5 in.) thick and under, two face-bend and two root-bend specimens for each position; for material over 12.5 mm (0.5 in.) thick, four side-bend specimens for each position involved. The bending jig and test requirements are indicated in 2-5-A1/Figure 11. Equivalent bending jigs, such as wrap around bend test fixtures, may also be used.
- *Test No. 3 – Fillet Weld Test* (2-5-A1/Figure 13).

13.9 Special Tests

All-weld-metal tensile, macro-etch, radiographic inspection or other relevant tests may be required for certain applications, and the results submitted for consideration.

15 Welder Qualifications

15.1 General

The Surveyor is to be satisfied that the welders and operators are proficient in the type of work which they are called upon to perform, either through requiring any or all of the tests outlined in the following paragraphs or through due consideration of the system of employment, training, apprenticeship, plant testing, inspection, etc., employed.

15.3 Qualification Tests

The tests, if required for qualification for various welding processes, are given in 2-5-A1/Table 6. Such tests are based on the material thicknesses and welding processes involved. Qualification of welders for a particular alloy may be acceptable for qualification of the welder for other aluminum alloys. Separate qualification tests are to be made for the gas metal arc and gas tungsten arc processes. The tests are referred to by Nos. Q1, Q2, Q4, and Q5, for which specimens are to be prepared and tested in accordance with 2-5-A1/Figure 14 to 2-5-A1/Figure 17, respectively. Specimens for qualification tests are to be bent in a bending jig having the profile shown in 2-5-A1/Figure 11 or in a bending jig having an equivalent wrap around design. Alternatively, upon the request of the employer, the welder may be qualified by use of radiography, provided that the complete particulars of the equipment available and the procedures are demonstrated to be satisfactory. Test assemblies for either mechanical testing or radiographic examination are to be prepared according to material thickness and welding position, as indicated in 2-5-A1/Table 6.

17 Alternatives

The foregoing are considered minimum requirements for aluminum welding in hull construction, but alternative methods, arrangements and details may be considered for approval.

TABLE 2
Minimum Mechanical Properties for Butt-Welded Aluminum Alloys

The adoption of test values higher than given in this table will be subject to special consideration. Filler wires are those recommended in 2-5-A1/Table 3. Values shown are for welds in plate thicknesses up to 38 mm (1.5 in.) unless otherwise noted.

Alloy	Ultimate Tensile Strength (U_{at})	Yield Strength (Y_{at}) ⁽²⁾	Shear Strength (τ_a) ⁽²⁾
	N/mm ² (psi)	N/mm ² (psi)	N/mm ² (psi)
5083-H111	269 (39000)	145 (21000)	83 (12000)
5083-H116, H321	276 (40000)	165 (24000)	96 (14000)
5083-H323, H343	276 (40000)	165 (24000)	96 (14000)
5086-H111	241 (35000)	124 (18000)	69 (10000)
5086-H112 6 mm (0.25 in.) –12 mm (0.50 in.)	241 (35000)	117 (17000)	65 (9500)
5086-H112 12 mm (0.5 in.) –25 mm (1.0 in.)	241 (35000)	110 (16000)	62 (9000)
5086-H112 Greater than 25 mm (1.0 in.)	241 (35000)	96.5 (14000)	55 (8000)
5086-H32, H34, H116	241 (35000)	131 (19000)	76 (11000)
5383-O, H111	290 (42000)	145 (21000)	83 (12000)
5383-H116, H321	290 (42000)	165 (24000) ⁽³⁾	83 (12000)
5383-H34	290 (42000)	145 (21000)	83 (12000)
5454-H111	214 (31000)	110 (16000)	65 (9500)
5454-H112	214 (31000)	83 (12000)	48 (7000)
5454-H32, H34	214 (31000)	110 (16000)	65 (9500)
5456-H111	283 (41000)	165 (24000)	96 (14000)
5456-H112	283 (41000)	131 (19000)	76 (11000)
5456-H116, H321	290 (42000)	179 (26000)	103 (15000)
5456-H323, H343	290 (42000)	179 (26000)	103 (15000)
6061-T6 ⁽¹⁾ under 9.5 mm (0.375 in.)	165 (24000)	138 (20000)	83 (12000)
6061-T6 ⁽¹⁾ over 9.5 mm (0.375 in.)	165 (24000)	103 (15000)	62 (9000)

Notes:

- 1 Values when welded with 4043, 5183, 5356 or 5556 filler wire.
- 2 Yield and shear strength is not required for weld procedure qualification.
- 3 Yield strength values as high as 185 N/mm² (27000 psi) have been satisfactorily demonstrated and statistically verified.

TABLE 3
Aluminum Alloy Filler Metal Composition

Composition in percent maximum unless shown as a range or specified. See also AWS A5.10

Alloy	Silicon	Iron	Copper	Manganese	Magnesium	Chromium	Zinc	Titanium	Other*		Aluminum
									Each	Total	
4043	4.5–6.0	0.80	0.30	0.05	0.05		0.10	0.20	0.05	0.15	Remainder
5183	0.40	0.40	0.10	0.50–1.0	4.3–5.2	0.05–0.25	0.25	0.15	0.05	0.15	Remainder
5356	0.25	0.40	0.10	0.05–0.20	4.5–5.5	0.05–0.20	0.10	0.06–0.20	0.05	0.15	Remainder
5554	0.25	0.40	0.10	0.50–1.0	2.4–3.0	0.05–0.20	0.25	0.05–0.20	0.05	0.15	Remainder
5556	0.25	0.40	0.10	0.50–1.0	4.7–5.5	0.05–0.20	0.25	0.05–0.20	0.05	0.15	Remainder

* The maximum Beryllium content of all filler wires is to be 0.0008%.

TABLE 4
Filler Metals for Welding Aluminum Alloy – Sheet, Plate and Extrusions (2011)

Recommendations in this table apply to gas shielded-arc welding processes.

Filler metal alloys 5183, 5356 and 5556 may be used interchangeably, provided that strength, ductility and corrosion resistance are suitable for the service conditions.

<i>Base Metal Alloys</i>	5083	5086	5383	5454 ⁽¹⁾	5456	6061, 6082
5083	5183	5356	5183	5356 ⁽¹⁾	5183	5356 ⁽¹⁾
5086	5356	5356	5356	5356 ⁽¹⁾	5356	5356 ⁽¹⁾
5383	5183	5356	5183	5356 ⁽¹⁾	5183	5356 ⁽¹⁾
5454 ⁽¹⁾	5356	5356	5356	5554 ⁽¹⁾	5356	5356 ⁽¹⁾
5456	5183	5356	5183	5356 ⁽¹⁾	5556	5356 ⁽¹⁾
6061, 6082	5356	5356	5356	5356 ⁽²⁾	5356	4043 ⁽²⁾

Notes:

- 1 5454 aluminum alloy welded with 5554 filler metal is generally recommended for above 65°C (150°F), such as for smoke stacks and engine room enclosures
- 2 5183 or equivalents may be used.

TABLE 5
Filler Metals for Welding Aluminum Alloy Castings to Castings and Plate

ASTM American Society for Testing and Materials

AA Aluminum Association

<i>Castings</i>		<i>SG70A SG70B, 357</i> <i>(Note 1)</i>	<i>5154, 5454, 6061</i> <i>(Note 2)</i>	<i>5456, 5083, 5086</i> <i>(Note 3)</i>
<i>ASTM</i>	<i>AA</i>			
SG70A	356.0	4043	4043	5356
SG70B	A356.0	4043	4043	5356
	357.0	4043	4043	5356

Notes:

- 1 Filler metal with same analysis as base metal is sometimes used.
- 2 5183, 5356, 5554, 5556 and 5654 may be used. In some cases they may provide higher weld ductility and higher weld strength. 5554 is suitable for elevated temperature service.
- 3 5183, 5356 or 5556 may be used. 4043 may be used for some applications where filler metal properties are not of primary concern.

TABLE 6
Welder Qualification Tests

Construction Material	Position in Which Welding is to be Done on Job		
	Flat, Horizontal, Vertical and Overhead	Flat and Vertical	Flat Position Only
On material of limited thickness 19.1 mm (3/4 in.) or less. See Note 1.	Test No. Q1 in vertical and overhead positions	Test No. Q1 in vertical position	Test No. Q1 in flat position
On material of unlimited thickness (any thickness) See Notes 1 and 2.	Test No. Q2 in vertical and horizontal positions	Test No. Q2 in vertical position	Test No. Q2 in flat position
On piping or tubing. See Note 3.	Test No. Q3 in horizontal and vertical positions	Test No. Q3 in horizontal and vertical fixed positions	Test No. Q3 in horizontal rolled position
For tack welders	Test No. Q5 in vertical and overhead positions	Test No. Q5 in vertical position	

Notes:

- 1 Where the maximum thickness of material on which a welder may have occasion to work throughout the period governed by a test is indeterminate, the Surveyor may, if desired, require the welder to qualify under unlimited thickness requirements.
- 2 Where the maximum plate thickness to be welded is between 19.1 mm (3/4 in.) and 38.1 mm (1 1/2 in.) qualification Test No. Q2 may, with the permission of the Surveyor, be conducted on plate of maximum thickness involved.
- 3 Welding operators qualified under the requirements of Test No. Q4 will be considered as qualified to make welds governed by Tests Nos. Q1 and Q2. Welding Operators qualified to weld on plate in the vertical position may be permitted to weld on pipe in the horizontal rolled position.

FIGURE 3
Permissible Unfairness in Aluminum Welded Structure

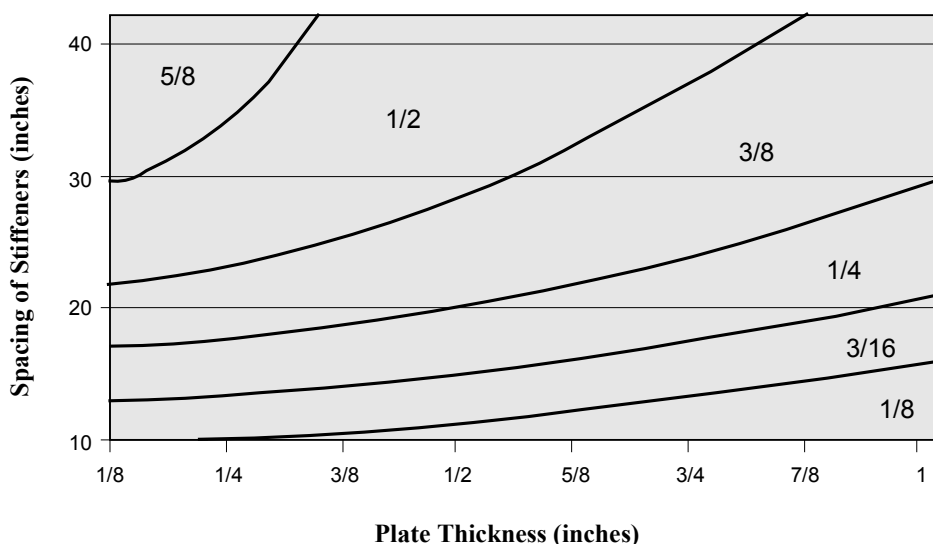

Applicability of tolerances:

- 1 Entire shell plating
- 2 Uppermost strength deck
- 3 Longitudinal strength Deck structure which includes inner-bottom tank tops
- 4 Bulwarks and exterior superstructure bulkheads

FIGURE 4
Permissible Unfairness in Other Aluminum Welded Structure

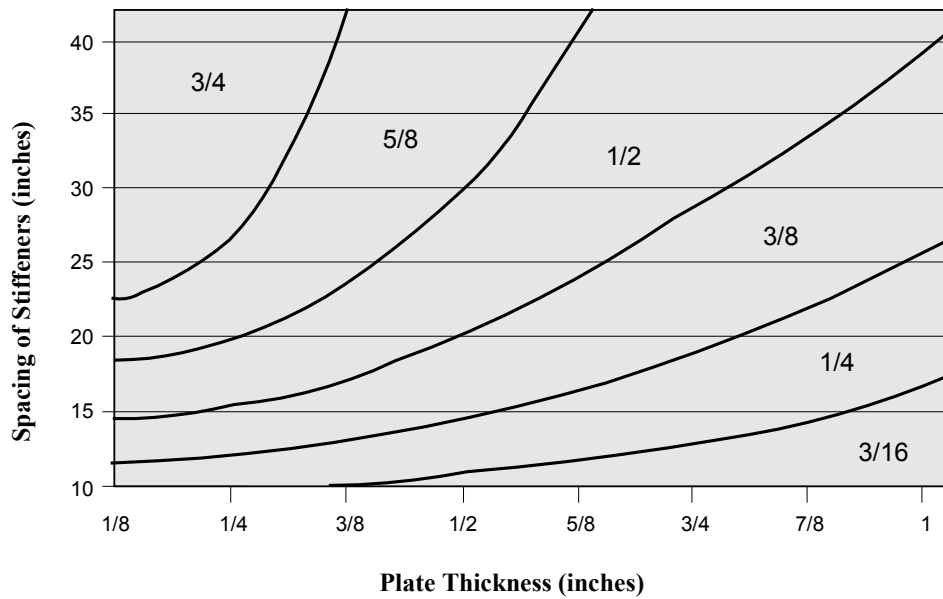

Applicability of tolerance

- 1 Structural bulkheads forming a boundary of living space (stateroom, office, berthing, messing or lounge area) and passageways contiguous to such spaces.
- 2 Decks within the hull and superstructure in way of the above living spaces.
- 3 Decks exposed to the weather.
- 4 Tank and main transverse bulkheads
- 5 Inner-bottom plate and longitudinals and transverses.

FIGURE 5
Preparation of Test Plates and Pipes for Weld Tests Nos. 1 and 2

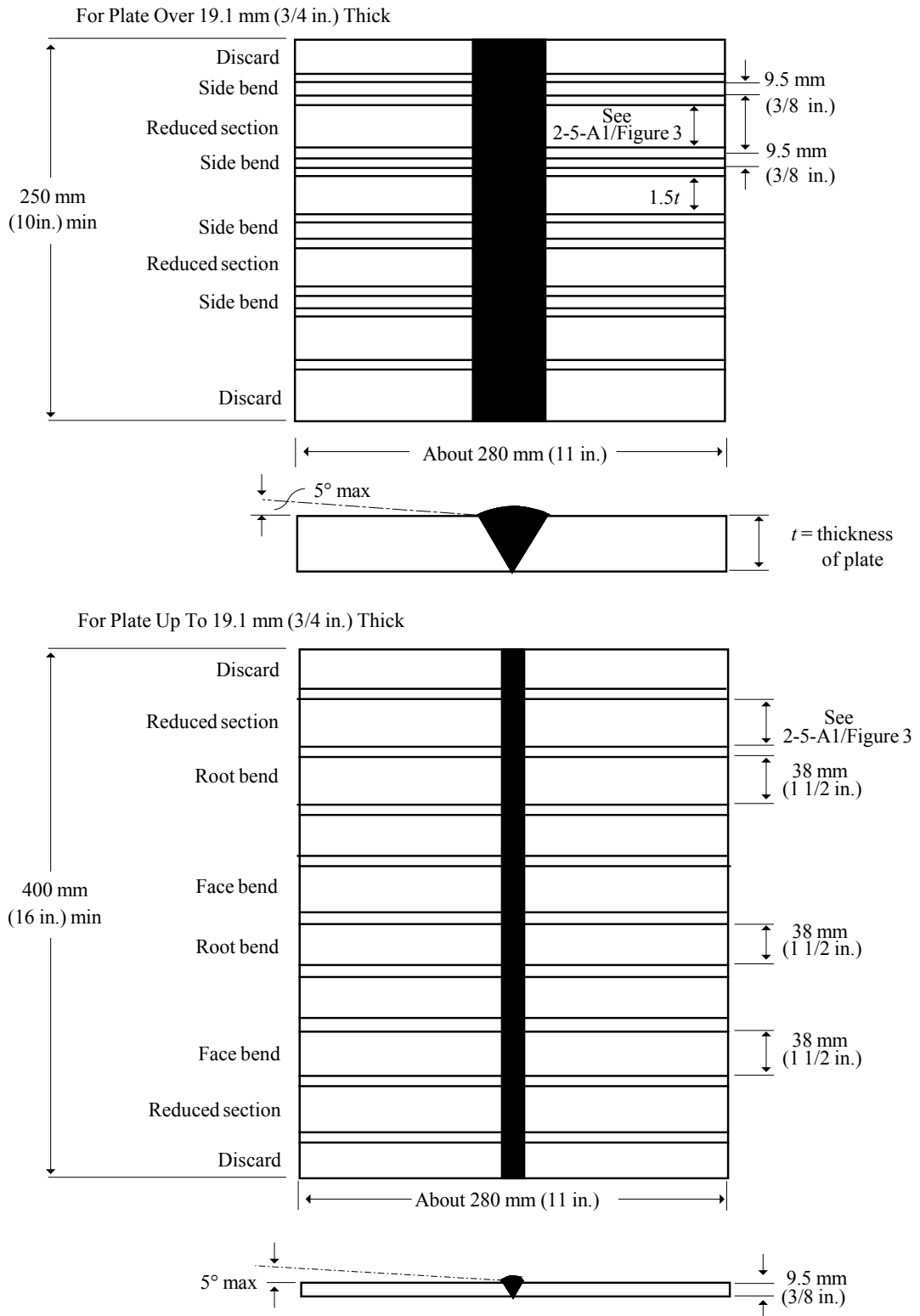

Note: Edge preparation, welding procedure and postweld heat treatment, if any, are to be the same as those for the work represented.

FIGURE 5 (continued) Preparation of Test Plates and Pipes for Weld Tests Nos. 1 and 2

For Pipe Over 19.1 mm (3/4 in.) Thick

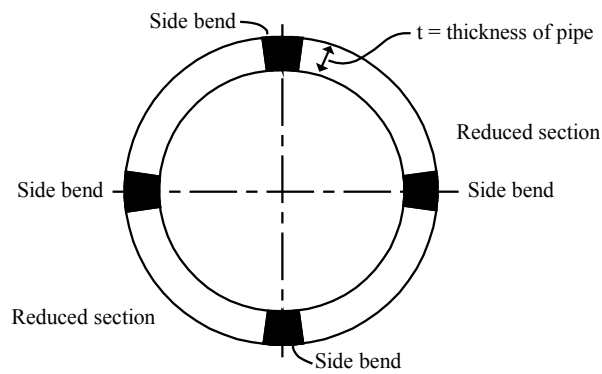

For Pipe Up To 19.1 mm (3/4 in.) Thick

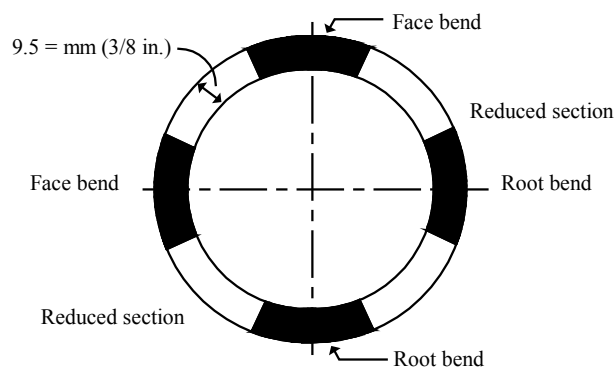

Note: Edge preparation, welding procedure and postweld heat treatment, if any, are to be the same as those for the work represented.

FIGURE 6
Typical Arrangement of Test Plates for Workmanship Tests in Group B1

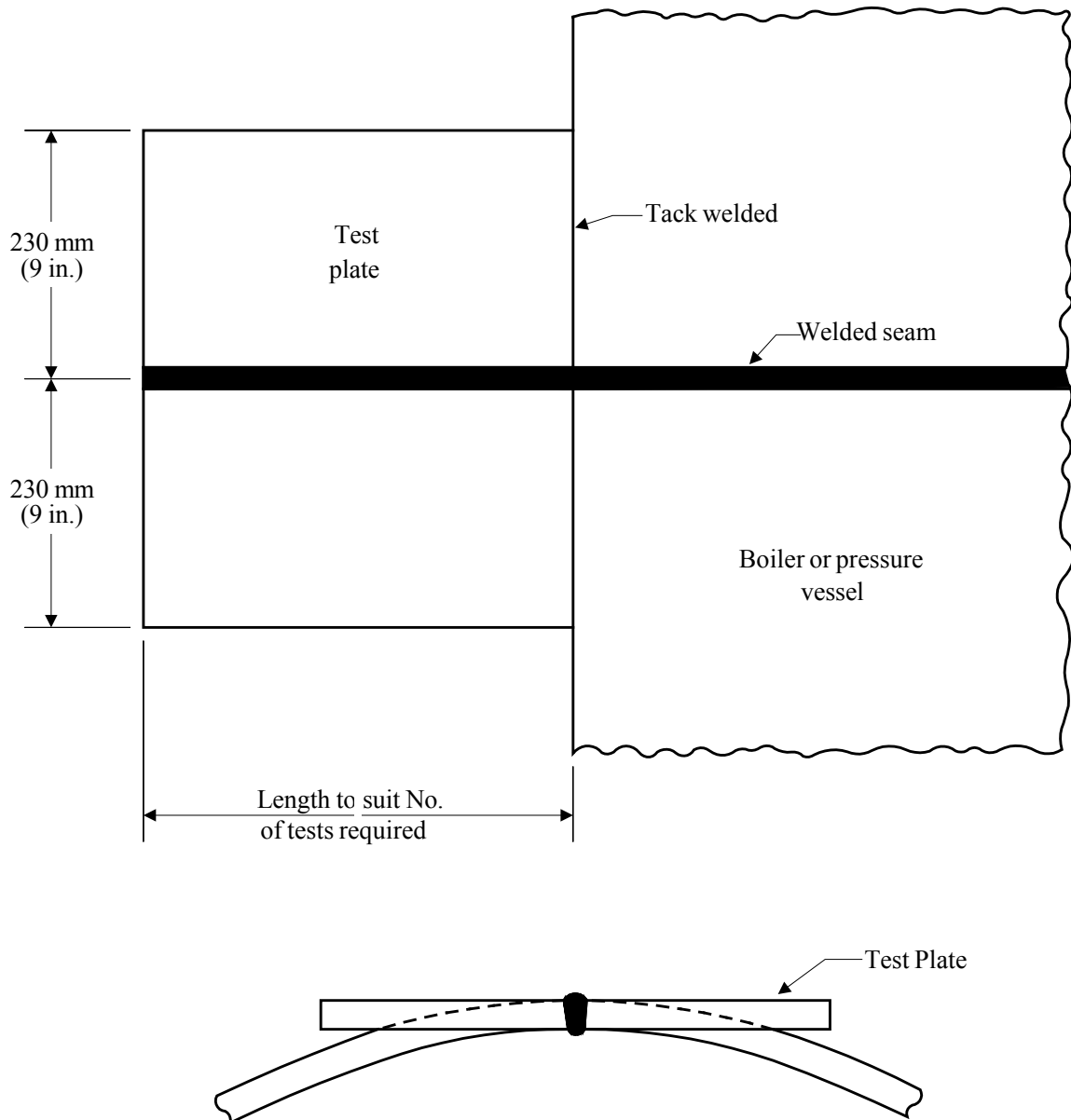

Note: Tack weld test plates together and support test assembly so that warping due to welding does not cause deflection of more than 5 degrees. Should straightening of any test assembly within this limit be necessary to facilitate making test specimens, the test assembly is to be straight-ended after cooling and before any postweld heat treatment.

FIGURE 7
Test No. 1 – Reduced-section Tension Test for Plate

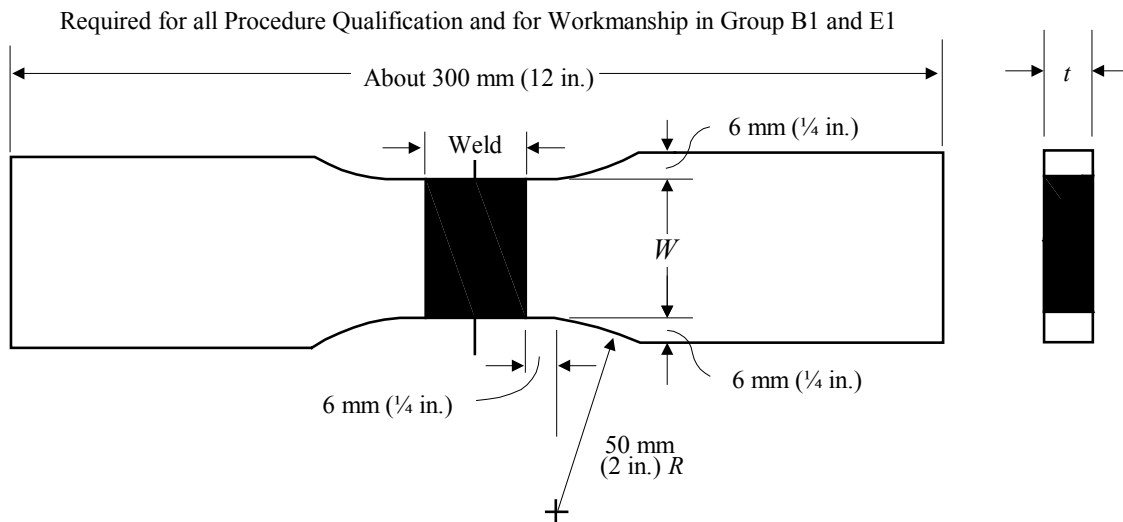

Notes

- 1 Both faces of weld are to be machined flush with base metal.
- 2 For procedure qualification, t is to be representative of thickness welded in production.
- 3 W = approximately 38 mm (1.5 in.) where t is 25.4 mm (1 in.) or less. w = 25.4 mm (1 in.) where t is more than 25.4 mm (1 in.)
- 4 When the capacity of the available testing machine does not permit testing the full thickness specimen, two or more thinner than full thickness specimens may be prepared by cutting the full thickness specimen into sections, each of which is to meet the requirements.

Requirement

The tensile strength of each specimen, when it breaks in or adjacent to the weld, is not to be less than the minimum specified tensile strength, as indicated in 2-5-A1/Table 2.

FIGURE 8
Test No. 1 – Reduced-section Tension Test for Pipe

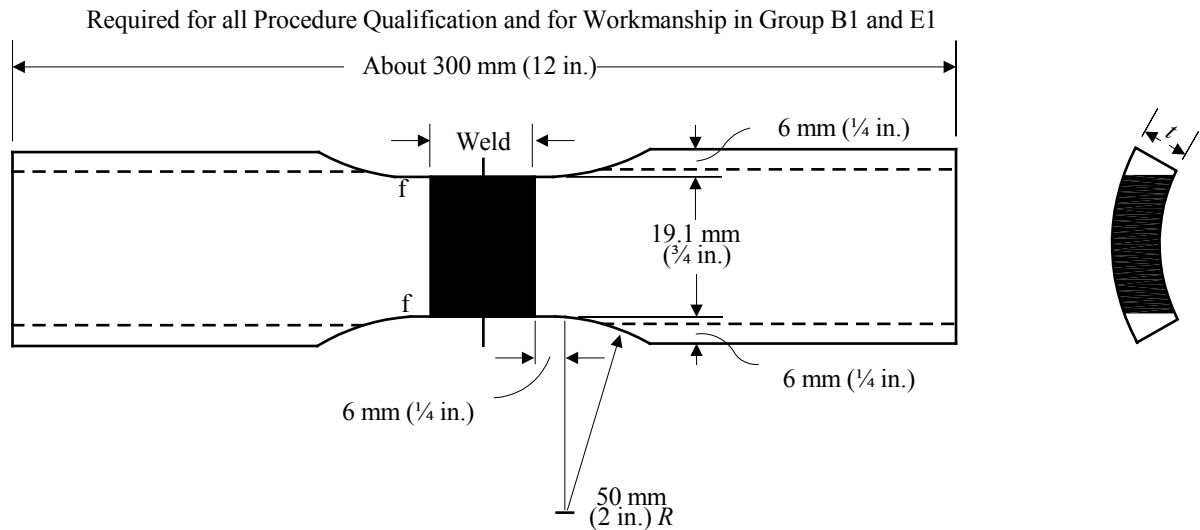

Notes

- 1 Both faces of weld are to be machined flush with base metal. The minimum amount needed to obtain plane parallel faces over 19.1 mm (3/4 in.) wide reduced section may be machined at the option of the testing facility.
- 2 For procedure qualification, $t = 9.5 \text{ mm}$ (3/8 in.) for construction materials up to 19.1 mm (3/4 in.). For construction material over 19.1 mm (3/4 in.), $t =$ thickness of material.
- 3 For workmanship tests, $t =$ thickness in material.
- 4 When the capacity of the available testing machine does not permit testing the full thickness specimen, two or more thinner than full thickness specimens may be prepared by cutting the full thickness specimen into sections, each of which is to meet the requirements.

Requirements

- 1 The tensile strength of each specimen when it breaks in or adjacent to the weld is not to be less than the minimum specified tensile strength, as indicated in 2-5-A1/Table 2.
- 2 The tensile strength of each specimen when it breaks in the base metal and the weld shows no signs of failure is not to be less than 95% of the minimum specified tensile strength of the base material.

FIGURE 9
Test No. 2 – Guided Bend Test for Root Bend and Face Bend
(Plate or Pipe) (2007)

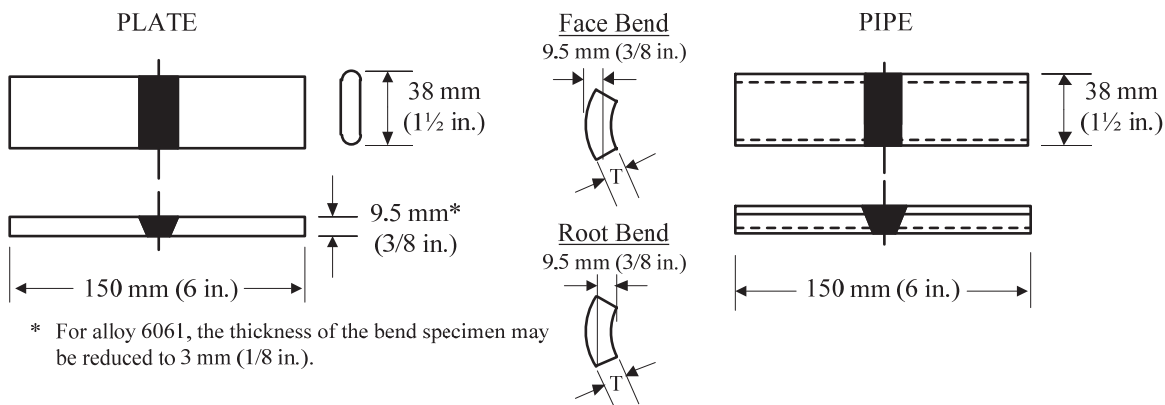

Note: Both faces of weld to be machined flush with base metal.
 On test assemblies greater than 9.5 mm (3/8 in.) the opposite side of specimen may be machined as shown.

FIGURE 10
Test No. 2 – Guided Bend Test for Side Bend (Plate or Pipe)

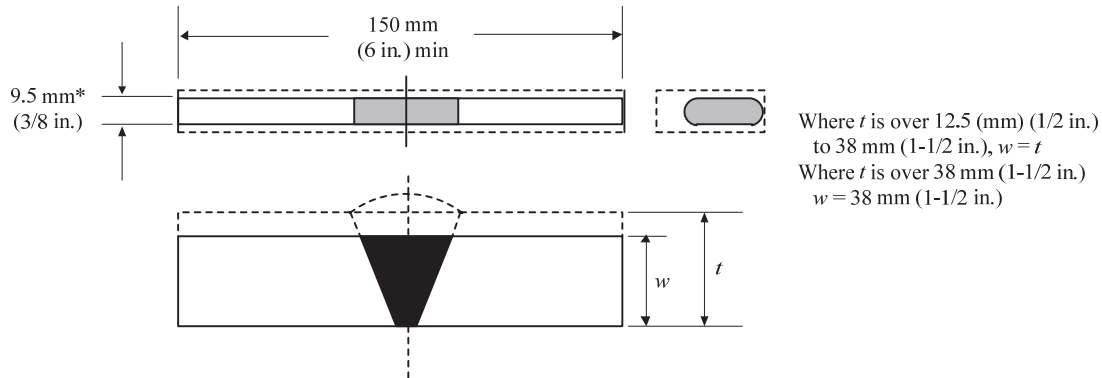

* For alloy 6061, the thickness of the bend specimen may be reduced to 3 mm (1/8 in.).

Note: Both faces of weld to be machined flush with base metal.

FIGURE 11
Guided Bend Test Jig

Test Requirement After bending, the specimen is not to show any cracking or other open defects exceeding 3.2 mm (1/8 in.) on the convex side, except at the corners.

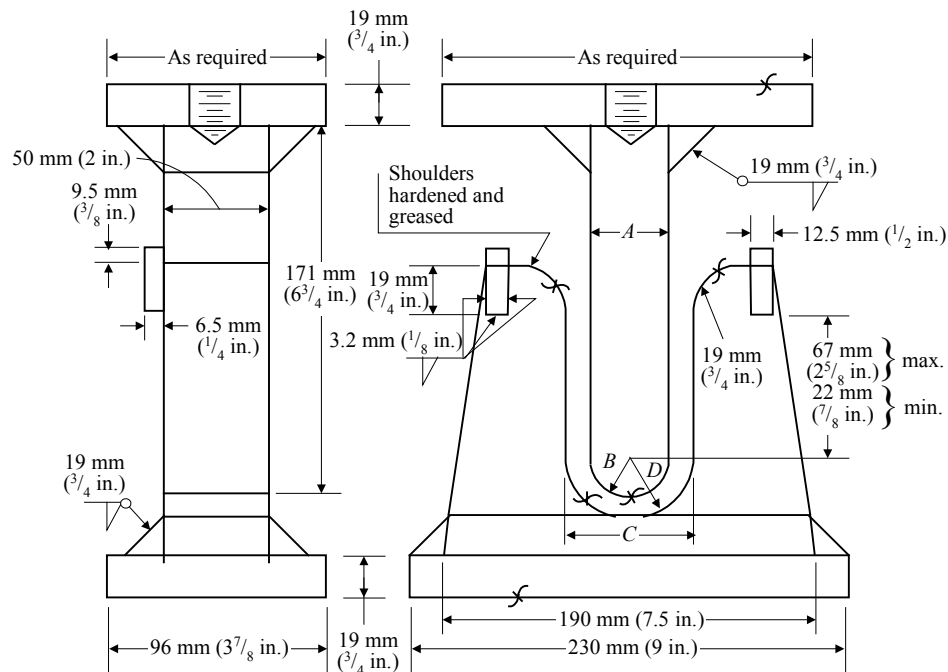

Applicable to material	Thickness of specimens	A	B	C	D
All alloys except 6061	t	$6\frac{2}{3}t$	$3\frac{1}{3}t$	$8\frac{2}{3}t + \frac{1}{8}$	$4\frac{1}{3}t + \frac{1}{16}$
Alloy 6061	3.2 mm (1/8 in.)	51.6 mm (2 1/16 in.)	26.2 mm (1 1/32 in.)	59.9 mm (2 3/8 in.)	30.2 mm (1 3/16 in.)

Note: Mandrel radius may be increased up to $8.25t$ maximum for alloy 6061.

FIGURE 12
Alternative Guided Bend Test Jig

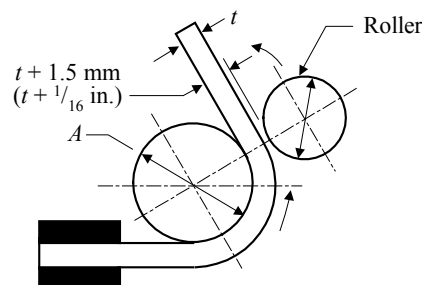

Notes:

- 1 The dimension t is the thickness of the material.
- 2 The reduced section is to be parallel within 0.05 mm (0.002 in.) and may have a gradual taper in width from the ends toward the center with the ends not more than 0.13 mm (0.005 in.) wider than the center. The ends of the specimens are to be symmetrical with the centerline of the reduced section within 0.25 mm (0.01 in.).
- 3 Mandrel radius may be increased up to $8.25t$ maximum for alloy 6061.
- 4 For aluminum alloy bend requirements, see 2-5-A1/Figure 10.

FIGURE 13
Test No. 3 – Fillet Weld Test (2013)

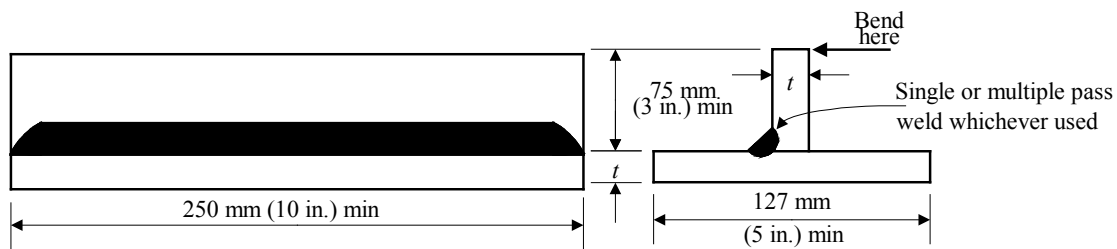

Notes:

- 1 For procedure qualifications, t is to be representative of thicknesses welded in production. Base and standing web is to be straight and in intimate contact and securely tacked at ends before fillet-weld is made, to insure maximum restraint.
- 2 (2013) The test plate may be cut into short sections to facilitate breaking open.

Requirements:

The fillet is to be the required contour and size, free from undercutting and overlapping. When broken as indicated, the fractured surface is to be free from cracks, and reasonably free from visible porosity and lack of root infusion, except that porosity or incomplete fusion at the root corners of fillets may be acceptable, provided the total length of the incompletely fused areas is less than approximately 10% of the total length of the weld.

FIGURE 14
Welder Qualification Test No. Q1

For plate material 19.1 mm (3/4 in.) or less.

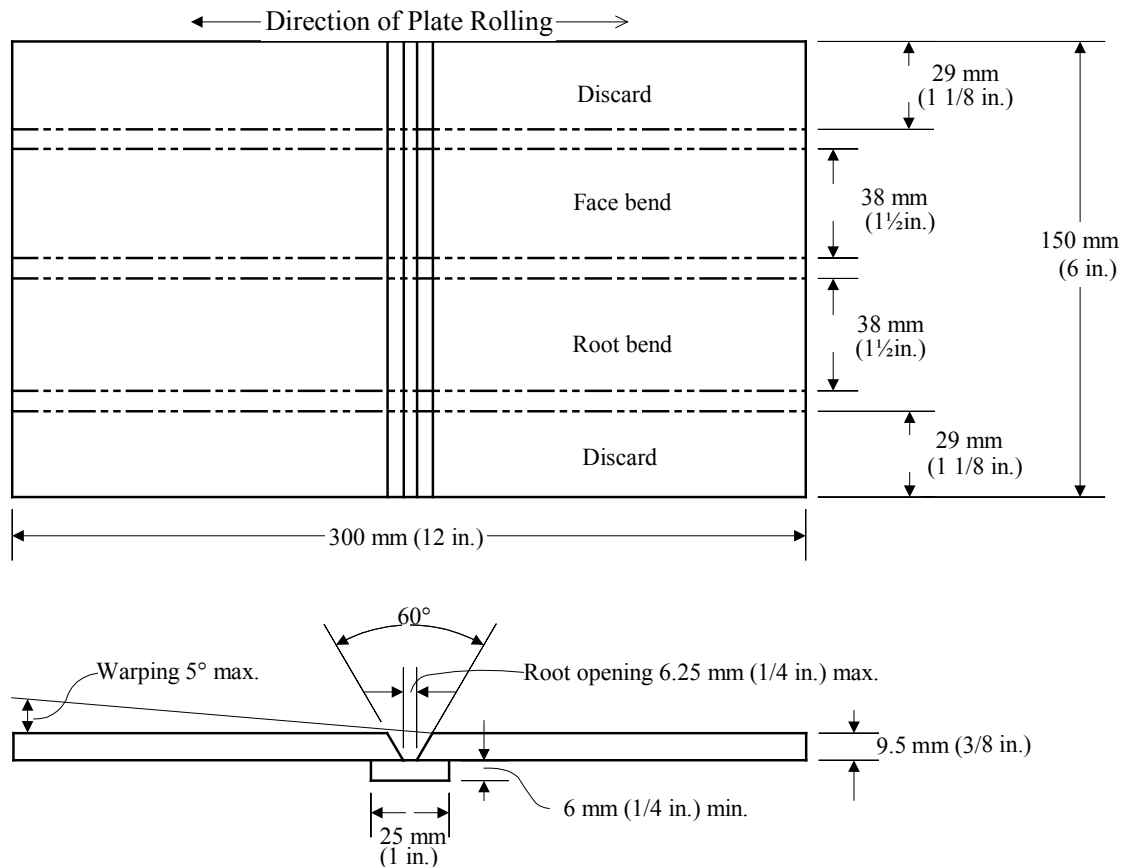

Notes:

- 1 Weld is to be made with the maximum size electrode that will be used in production and a maximum interpass temperature of 66°C (150°F).
- 2 Machine reinforcement and backing strap flush. Do not remove any undercutting.
- 3 Machining is to be done transverse to weld.
- 4 All specimens are to be machined or sawed from plate.
- 5 Backing strap is to be contiguous with plates.
- 6 Joints welded in the vertical position are to be welded upwards.
- 7 Welding is to be done from one side only.
- 8 Bend specimens in Guided Bend Test Jig (2-5-A1/Figure 10 or 2-5-A1/Figure 11).
- 9 1 Face Bend and 1 Root Bend required.

FIGURE 15
Welder Qualification Test No. Q2

For material of unlimited thickness.

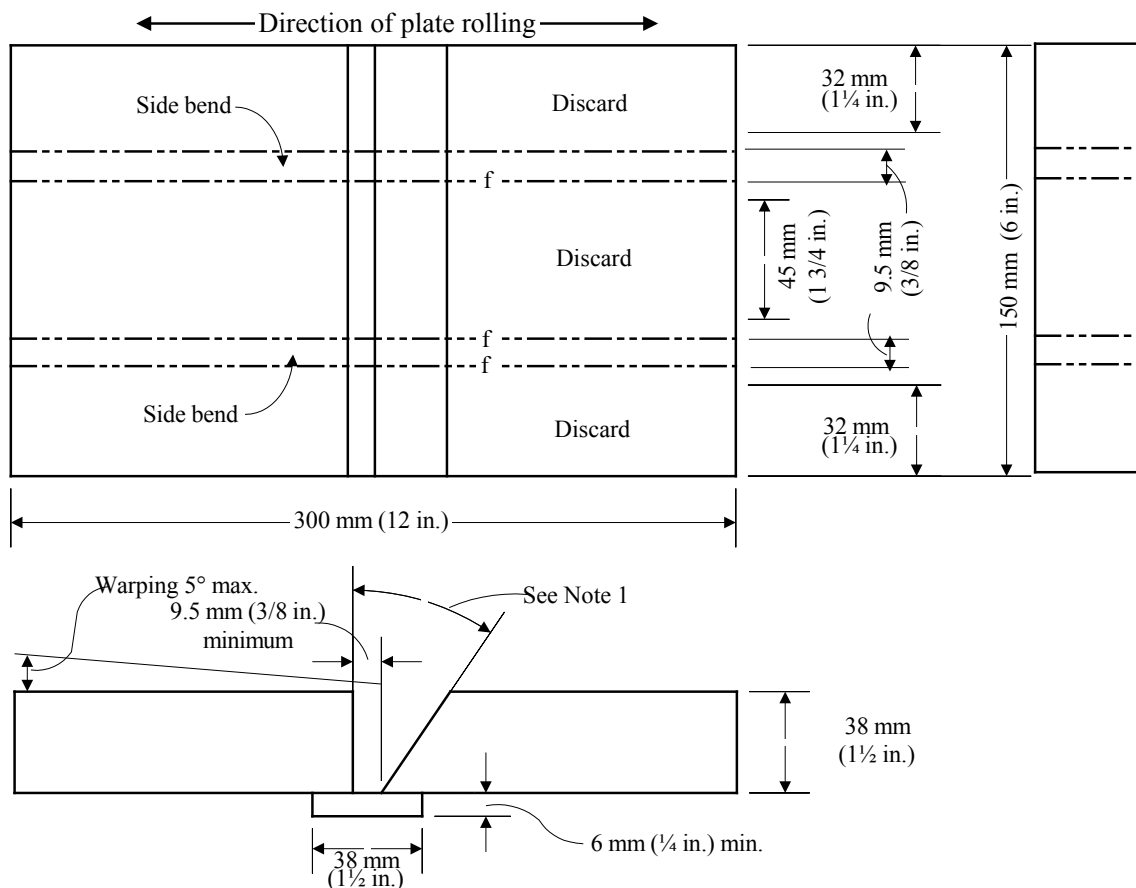

Notes:

- 1 When welding in the flat and vertical positions of welding, the groove angle is to be 25 degrees; when welding in the horizontal position, the groove angle is to be 35 degrees and the unbeveled plate is to be located on the top side of the joint.
- 2 Backing strap is to be contiguous with plates.
- 3 Each pass of the weld is to be made with the same size electrode that will be used in production and a maximum interpass temperature of 66°C (150°F).
- 4 Joints welded in the vertical position are to be welded upwards.
- 5 Welding is to be done from one side only.
- 6 Machine reinforcement and backing strap flush. Do not remove any undercutting.
- 7 All specimens are to be machined or sawed from plate.
- 8 Machining is to be done transverse to weld.
- 9 Break edges of specimens to a radius of $t/6$ maximum.
- 10 Bend Specimen in Guided Bend Test Jig (2-5-A1/Figure 10 or 2-5-A1/Figure 11).
- 11 2 Side Bends required for plate. 4 Side Bends required for pipe.

FIGURE 16
Welder Qualification Test No. Q4

For pipe 19.1 mm ($3/4$ in.) thick or less.

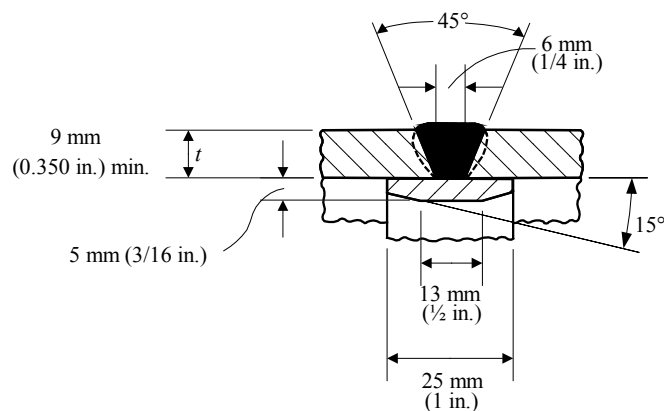
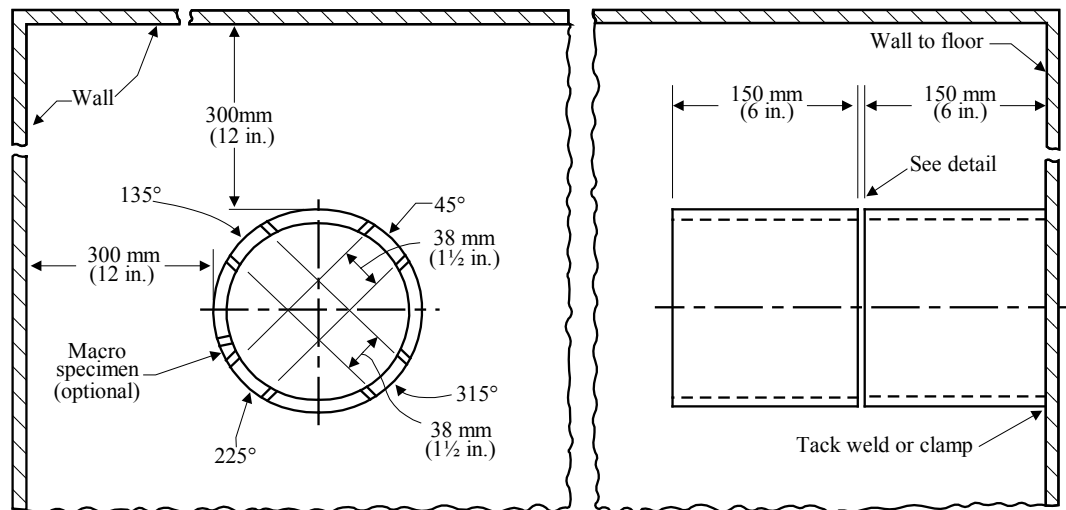

Use 150 mm (6 in.) piping (min.)

Notes:

- 1 Each pass of the weld is to be made with the same size electrode that will be used in production and a maximum interpass temperature of 66°C (150°F).
- 2 Machine reinforcement and backing strap flush. Do not remove any undercutting.
- 3 Machining is to be done transverse to weld.
- 4 All specimens are to be machined or sawed from piping.
- 5 Break edges of specimens to a radius of $t/6$ maximum.
- 6 Mark top and front of piping to insure proper location of specimens.
- 7 Remove face-bend specimens from 45 degree and 225 degree points, and root-bend specimens from 135 degree and 315 degree points, as indicated.
- 8 Welding is to be done from one side only.
- 9 Bend Specimen in Guided Bend Test Jig (2-5-A1/Figure 10 or 2-5-A1/Figure 11).
- 10 Two Root Bends and two Face Bends required.
- 11 For thicknesses over 19.1 mm ($3/4$ in.), t is to be a minimum of $1/2$ of the thickness to be welded in production.
- 12 For GTA welding, no backing bar need be employed and root opening may be reduced to zero.

FIGURE 17
Welder Qualification Test No. Q5

For Tack Welders.

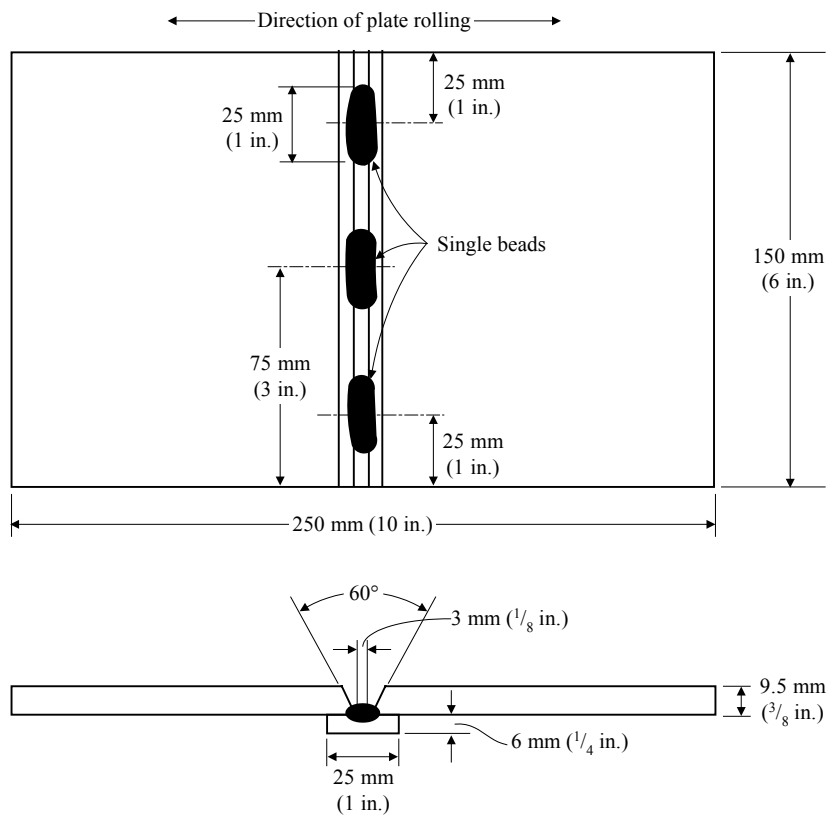

Notes:

- 1 Electrode diameter used is to be representative of that used for tack welding in production.
- 2 Backing strap is to be contiguous with plates.
- 3 Joints welded in the vertical position are to be welded upwards.
- 4 Specimen is to be bent in one piece with backing strap in place and face of weld in tension.
- 5 Weld fractures are to exhibit no unfused areas on backing strap or sides of groove throughout length of each tack.
- 6 For GTA welding, no backing bar need be employed and root opening may be reduced to zero.

PART 2

CHAPTER 5 Materials for Hull Construction – Aluminum

APPENDIX 2 Requirements for the Approval of Aluminum Filler Metals

1 General

1.1 Scope

These requirements give the conditions of approval and inspection for welding consumables to be used in hull construction and marine structures using aluminum alloys according to Part 2, Chapter 5. Where no special requirements are given herein, e.g., for the approval procedure or for welding of test assemblies and testing, those of Part 2, Appendix 2 apply in analogous manner.

The welding consumables preferably to be used for aluminum alloys concerned are divided into two categories as follows:

W = Wire electrode, and wire-gas combinations for GMAW, GTAW, or PAW

R = Rod-gas combinations for GTAW

1.3 Grading, Designation

1.3.1

Consumables are graded as indicated in 2-5-A2/Table 1, in accordance with the alloy type and strength level of base materials used for approval tests.

**TABLE 1
Consumable Grades and Base Materials for the Approval Test (2009)**

<i>Consumable Quality Grade (Symbol)</i>	<i>Base Materials for Tests</i>	
	<i>Alloy Designation</i>	
	<i>Numerical</i>	<i>Chemical Symbol</i>
RA/WA	5754	AlMg3
RB/WB	5086	AlMg4
RC/WC	5083	AlMg4.5Mn0.7
	5383	AlMg4.5Mn0.9
	5456	AlMg5
	5059	-----
RD/WD	6005A	AlSiMg(A)
	6061	AlMg1SiCu
	6082	AlSi1MgMn

Note: Approval on higher strength AlMg base materials covers also the lower strength AlMg grades and their combination with AlSi grades.

1.3.2

Approval of a wire or a rod will be granted in conjunction with a specific shielding gas according to 2-5-A2/Table 2 or defined in terms of composition and purity of “special” gas to be designated with group sign “S”. The composition of the shielding gas is to be reported. The approval of a wire or rod with any particular gas can be applied or transferred to any combination of the same wire or rod and any gas in the same numbered group as defined in 2-5-A2/Table 2, subject to the agreement of ABS.

TABLE 2
Compositional Limits of Shielding Gases and Mixtures to be Used

Group	Gas composition (Vol.%)	
	Argon	Helium
I-1	100	---
I-2	---	100
I-3	Rest	>0 to 33
I-4	Rest	>33 to 66
I-5	Rest	>66 to 95
S ⁽¹⁾	Special gas, composition to be specified; see 2-5-A2/1.3.2	

Note:

- Gases of other chemical composition (mixed gases) may be considered as “special gases” and covered by a separate test.

1.5 Manufacture, Testing and Approval Procedure

Manufacturer’s plant, production methods, and quality control measures shall be such as to ensure reasonable uniformity in manufacture; see also Part 2, Appendix 2.

Testing and approval procedure shall be in accordance with Section 2-A2-1 for the individual categories (types) or welding consumables, shielding gases, and gas mixtures mentioned in 2-5-A2/1.1 above.

3 Testing and Required Properties

3.1 Testing of the Deposited Weld Metal

For testing the deposited weld metal chemical composition, a test piece according to 2-5-A2/Figure 1 shall be prepared. The size depends on the type of the welding consumable (and on the welding process) and shall give a sufficient amount of pure weld metal for chemical analysis. The base metal used shall be compatible with the weld metal with respect to chemical composition.

FIGURE 1
Deposited Weld Metal Test Assembly

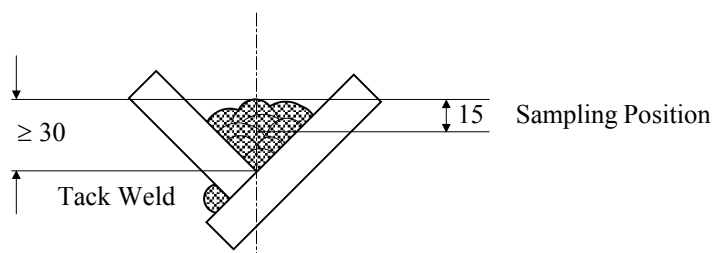

The chemical composition of the deposited weld metal shall be determined and certified in a manner analogous to that prescribed in 2-A2-1/13. The results of the analysis shall not exceed the limit values specified by the manufacturer.

3.3 Testing of Butt Weld Assemblies

Testing of the welded joints shall be performed on butt-weld test assemblies according to 2-5-A2/Figures 2 and 3, made from materials as given in 2-5-A2/Table 1, in an analogous manner to 2-A2-1/17 and 2-A2-4/7.

Butt weld test assemblies according to 2-5-A2/Figure 2 with a thickness of 10 to 12 mm ($\frac{3}{8}$ to $\frac{1}{2}$ in.) are to be prepared for each welding position (flat, horizontal, vertical-up, and overhead) for which the consumable is recommended by the manufacturer; except that consumables satisfying the requirements for flat and vertical-up positions will be considered as also complying with the requirements for horizontal position.

Additionally, one test assembly according to 2-5-A2/Figure 3 with thickness of 20 to 25 mm ($\frac{3}{4}$ to 1 in.) is to be welded in the flat position only.

FIGURE 2
Butt Weld Test Assembly for Out-of-position Welding

- T = Flat tensile test specimen
- B_C = Face bend test specimen
- B_R = Root bend test specimen
- M = Macrographic section

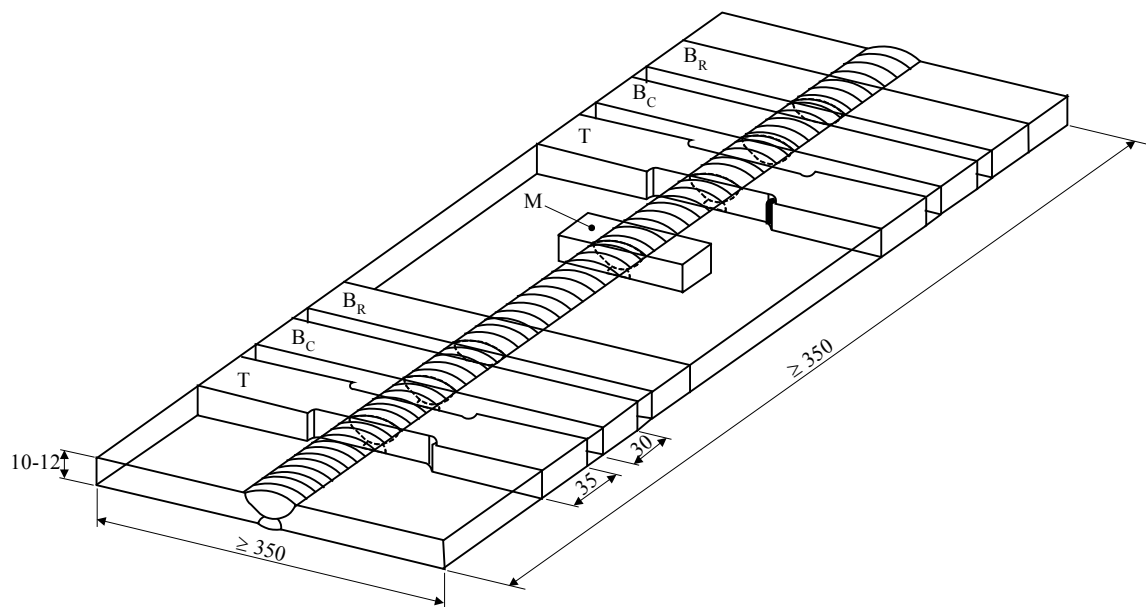

Notes:

- 1 Edge preparation is to be single V or double V with 70° angle.
- 2 Back sealing runs are allowed in single V weld assemblies.
- 3 In case of double V assembly, both sides shall be welded in the same welding position.

FIGURE 3
Butt Weld Test Assembly in Flat Position

- T = Flat tensile test specimen
- B_C = Face bend test specimen
- B_R = Root bend test specimen
- M = Macrographic section

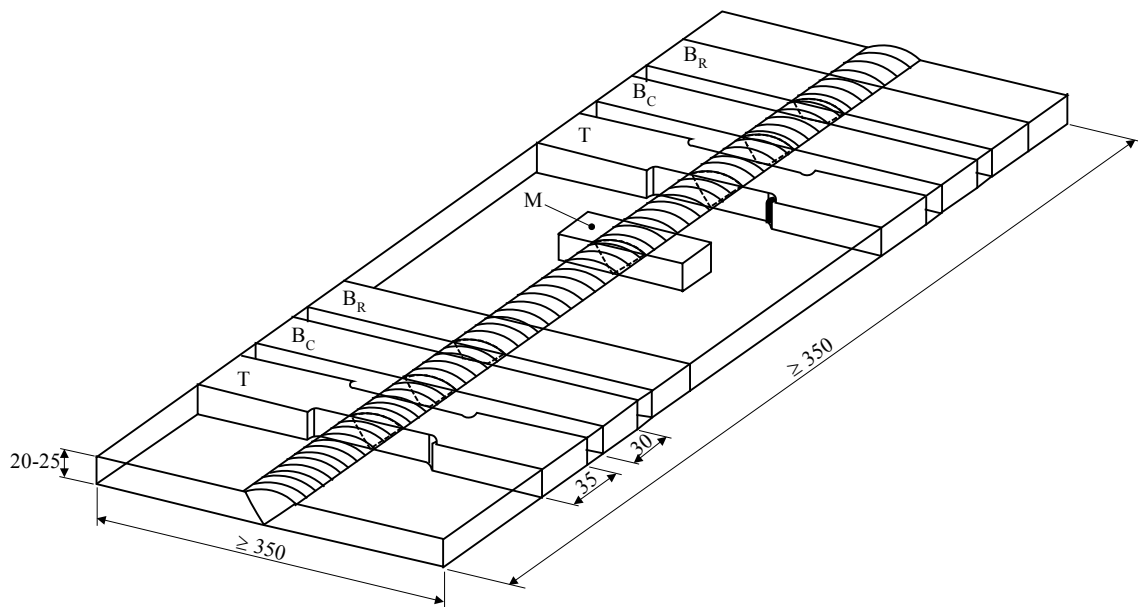

Notes:

- 1 Edge preparation is to be single V with 70° angle.
- 2 Back sealing runs are allowed.

On completion of welding, assemblies must be allowed to cool naturally to ambient temperature. Welded test assemblies and test specimens must not be subjected to any heat treatment. Grade D assemblies should be allowed to naturally age for a minimum of 72 hours after completion of welding before testing is carried out.

Test specimens shown in 2-5-A2/Figures 2 and 3 and described in Section 2-A2-4 shall be taken from the butt weld test assemblies.

The mechanical properties must meet the requirements stated in 2-5-A2/Table 3. The provisions of Section 2-A2-1 apply in analogous manner to the performance of the tests, including requirements for annual check tests and retesting. The position of the fractures is to be stated in the report. The macrographic specimen shall be examined for imperfections such as lack of fusion, cavities, inclusions, pores, and cracks.

TABLE 3
Requirements for the Transverse Tensile and Bend Tests (2009)

<i>Grade</i>	<i>Base Material Used for the Test</i>	<i>Tensile strength R_m, N/mm² (ksi) min.</i>	<i>Former Diameter</i>	<i>Bending angle ⁽¹⁾ [degrees] min.</i>
RA/WA	5754	190 (27.5)	3t	180
RB/WB	5086	240 (35)	6t	
RC/WC	5083	275 (40)	6t	
	5383 or 5456	290 (42)	6t	
	5059	330 (47)	6t	
RD/WD	6005A, 6021, or 6082	170 (24.5)	6t	

Note:

- 1 (2009) During testing, the test specimen shall not reveal any one single flaw greater than 3 mm in any direction. Flaws appearing at the corners of a test specimen shall be ignored in the evaluation unless there is evidence that they result from lack of fusion.

5 Annual Check Tests

Annual check tests shall entail the preparation and testing of the deposited weld metal test assembly as prescribed in 2-5-A2/Figure 1 and of the flat position butt weld test assembly according to 2-5-A2/Figure 2.

CHAPTER 5 Materials for Hull Construction – Aluminum**APPENDIX 3 Scheme for the Approval of Aluminum Manufacturers****1 Scope (2013)**

In accordance with 2-5-1/1.3, this Appendix provides specific requirements for the approval of manufacturers of aluminum plate, sheet, extrusions, castings, and forgings. The manufacturer approval scheme is intended to certify the manufacturer's capability of furnishing satisfactory products in a consistent manner under effective process and production controls in operation.

3 Approval Application**3.1 Initial Approval**

For consideration to produce ABS-certified aluminum alloy plate and sheet or extrusions, the manufacturer is to apply for approval of the process of manufacture by submitting information and supporting test data to ABS Houston Materials Department, or alternatively to the local Surveyor who attends the facility who is to include this information with the survey report.

3.3 Content of Application

The submittal is to be specific to the Alloy and Temper, product form, maximum thickness, melting practice, casting practice and heat treatment or special rolling or extrusion practice for which approval is sought. At the option of the facility, this submittal may be preceded by a proposed test program to assure that the appropriate testing is scheduled.

3.5 Information and Data Required for Approval

The following summarizes the minimum information and test data required for approval as well additional requirements for special alloys, claimed to exhibit superior properties.

3.5.1 Production and Process Information

- i)* Plant tonnage capacity
- ii)* Product type and grade
- iii)* Maximum thickness
- iv)* Melting, refining and pouring practices
 - Furnace type
 - Melting practice-including charges of metallics and slag
 - Ladle additions
 - Refining practice
 - Pouring practice
 - Reheating furnace equipment and practices
 - Special rolling or extrusion practices

- Inspection practices
- Heat treatment equipment and procedure if applicable
- Nondestructive testing procedures

3.5.2 Test Data (2013)

- i) Sketch showing locations of test coupons
- ii) Tension Test Specimen
 - At least two tension specimens from two different locations of the sample or from two samples are to be taken for each qualification testing
 - Rectangular full-thickness specimens for thickness of less than 12.5 mm (0.5 inch).
 - Round specimens for thicknesses of 12.5 mm (0.5 inch) and greater. For material thickness of 12.5 mm (0.5 inch) and up to 40 mm (1.5 inch), tensile specimens to be from mid-thickness or of full-section. For thickness over 40 mm (1.5 inch), two specimens are to be taken from $1/2$ and $1/4$ thickness.
- iii) Tension Test Specimen Orientation
 - Nonheat-treatable Sheet/Plate – longitudinal
 - Heat-treatable Sheet/Plate – long-transverse
 - Heat-treatable Extrusion/Section – longitudinal
 - Forging – longitudinal (specimen axis parallel to grain flow direction)
- iv) Tension Test Data
 - Yield Point (or Strength)
 - Ultimate Tensile Strength
 - Elongation
- v) Chemical Analysis
 - Ladle and Product
 - Fe, Si, Cu, Mn, Mg, Cr, Zn, Ti
 - Plus any other intentionally added element
- vi) Metallographic Examination
 - Photomicrographs – at surface, $1/4$ thickness and mid-thickness locations
 - Microstructure – longitudinal at 100× and 500×, unetched and etched
 - Photomacrograph – etched
 - Transverse from center width of slabs
 - Transverse from center width of plates
 - Full transverse section of shapes and bars

Rolled plate/sheet and extruded sections are to be tested for minimum and maximum approval thickness. The extent of testing for minimum thickness may be reduced to tensile test, photomacrograph examination and micrographic examination at mid-thickness if the test scope is accepted by ABS Materials Department.

Drift expansion tests for extruded closed profiles are to be carried out as indicated in 2-5-8/5.3.

Corrosion testing for Rolled 5xxx alloys in H116 and H321 tempers is to be carried out in accordance with G66 and G67 or equivalent standards satisfying the acceptance criteria as indicated in 2-5-6/3.

The photomicrographs and photomacrographs are considered acceptable if they are representative of metallurgically sound material.

3.7 Superior Properties

In the event that aluminum alloys which are claimed to exhibit superior properties are the subject of the approval, the additional test data for special alloys that are listed below will also be required as part of the test program.

Additional Test Data for Special Aluminum Alloys*

<i>Test Data</i>	<i>Special Alloy</i>
Fracture Test	Specific Fracture Criterion
Weldability Test	Superior Weldability
Corrosion Tests – ASTM G 66 and G 67	Superior Corrosion Resistance
Ultrasonic Inspection	Superior Internal Quality

* The alloy and temper designations should be denoted when reporting the data

3.9 ABS Activity in the Approval Process

<i>Topic</i>	<i>MMPS</i>	<i>Attending Surveyor</i>
Process/Production Information	Technical Review	Verification by Plant Survey
Proposed Test Program*	Technical Review	---
Material Test Data	Technical Review	Witness of Mechanical Testing**

* Optional

** Not necessary during production testing for manufacturing facilities participating in the ABS Quality Assurance Program

5 Renewal of Approval (2011)

The validity of the approval is to be to the maximum of five years, renewable subject to an audit and assessment of the result of satisfactory survey during the preceding period. The Surveyor's report confirming no process changes, along with chemical, mechanical, and corrosion, if applicable, property statistical data for various approved grades, is to be made available to the ABS Engineering/Materials department for review and issuance of renewal letter/certificate.

Manufacturers who have not produced the approved grades and products during the period preceding the renewal may be required to carry out approval tests, unless the results of production of similar grades of products during the period are evaluated by ABS and found acceptable for renewal.

PART
2

CHAPTER **6** **Materials for Hull Construction – Fiber Reinforced
Plastics (FRP)**

CONTENTS

SECTION 1	General	77
1	Resins	77
1.1	Polyester Resins	77
1.3	Vinylester and Epoxy Resins.....	77
1.5	Gel Coats	77
1.7	Curing Systems	77
1.9	Phenolic Resins.....	77
1.11	Resin Properties.....	77
1.13	Additives.....	78
1.15	Fillers.....	78
3	Reinforcing Materials	78
5	Core Materials.....	79
5.1	PVC Foam Cores	79
5.3	Balsa Wood	79
5.5	Core Bonding Materials	79
7	Laminates	79
7.1	Basic Laminate.....	79
7.3	Uni-directional Laminates	80
7.5	Bi-Directional Laminates.....	80
7.7	Sandwich Laminates	80
7.9	Mechanical Properties	80
7.11	Nonstructural Plies	80
7.13	Laminate Thickness	80
7.15	Plywood and Timber Members.....	81
9	Adhesives	82
9.1	General.....	82
9.3	Requirements for Structural Application	82
TABLE 1	Properties of Core Materials	79
TABLE 2	FRP Laminate Properties.....	81
SECTION 2	Fabrication	83
1	General	83
3	Fabrication Procedures.....	83
3.1	General.....	83
3.3	Laminate Layup.....	83
3.5	Sandwich Panel Layup.....	83
3.7	Secondary Bonds	84

SECTION 3	Building Process Description	85
1	General	85
3	Building Facilities	85
3.1	Material Storage Premises	85
3.3	Mold Construction.....	86
3.5	Laminating Premises	86
3.7	Equipment	87
5	Specifications and Data Sheets for Materials	88
5.1	Resins, Gel Coats, Catalysts, Accelerators, Hardeners and Other Additives	88
5.3	Reinforcing Materials	88
5.5	Core Materials	88
7	Receiving Materials.....	88
7.1	Resins, Gel Coats, Catalysts, Accelerators, Hardeners and Other Additives	88
7.3	Reinforcing Materials	88
7.5	Core Materials	88
9	Laminating Procedure	88
9.1	Start-up.....	88
9.3	Application of Gel Coat	89
9.5	Lamination of Skin Coat.....	89
9.7	Main Lamination – Single Skin	90
9.9	Main Lamination – Sandwich Laminate	91
9.11	Release and Curing	92
9.13	Secondary Bonding	92
11	Inspection.....	93
11.1	General.....	93
11.3	Voids.....	93
13	Faults	94
13.1	General.....	94
13.3	Production Faults.....	94
SECTION 4	Quality Control	95
1	Application.....	95
3	Definitions	95
3.1	Hull Construction	95
3.3	Quality Assurance Standard	95
3.5	Quality Assurance.....	95
3.7	Quality Assurance System.....	95
3.9	Building Process Description	95
3.11	Quality Control	95
3.13	Inspection	95
3.15	Assessment	96
3.17	Audit	96
3.19	System Monitoring	96
5	Design.....	96
5.1	Plan Review.....	96
5.3	Revisions	96

7	Building Process Description – Quality Control	96
9	Certification of Quality Assurance	96
11	Documentation of Quality Assurance System	96
13	Personnel	97
15	Internal Audit	97
17	Documentation	97
19	Purchase	97
21	Material Receipt, Inspection and Storage	98
23	Production	98
25	Production Inspections and Tests	99
27	Final Inspection	99
29	Nonconforming Materials and Components	99
31	Corrective Action	99
33	Calibration and Maintenance of Equipment	100
35	Training	100
37	Records	100
SECTION 5 Testing		102
1	Gel Time	102
3	Barcol Hardness	102
5	Burnout and Thickness	102
7	Void Content	102
9	Laminate Properties	103
11	Test Results	103
TABLE 1	Tests for Physical Properties of FRP Laminates	103
SECTION 6 Repair		104
1	General	104
3	Materials	104
3.1	Resins	104
3.3	Fiber Reinforcements	104
5	Repair Procedures – Single Skin Laminate	104
5.1	Damage Assessment	104
5.3	Removal of Damaged Laminate	105
5.5	Laminating Procedures	107
5.7	Laminating Process	108
7	Repair Procedure – Sandwich Construction	117
7.1	Damage Assessment	117
7.3	Removal of Damaged Laminate	117
7.5	Laminating Procedure and Process	117
9	Repair Acceptance	117
FIGURE 1	Scarf Joint Preparation	106
FIGURE 2	Repair Sequence	107
FIGURE 3	Ply Overlap Requirements	108

FIGURE 4	Partially Through Thickness Defect Repair	109
FIGURE 5	Double Sided Scarf Repair	110
FIGURE 6	One Sided Scarf Repair – Backing Plate Installation.....	111
FIGURE 7	Repair Using Defective Section as Backing Plate	112
FIGURE 8	Single Sided Scarf Repair on Thin Laminate.....	113
FIGURE 9	Backing Plate Installation – Access from One Sided Repair.....	114
FIGURE 10	Repair in Way of Through Bolt Failure.....	115
FIGURE 11	Stepped Angle Defect Repair	116

PART

2

CHAPTER 6 Materials for Hull Construction – Fiber Reinforced Plastics (FRP)

SECTION 1 General

1 Resins

Resins for the basic laminate of these Rules, other than those utilized for gel coats, are to be unsaturated, general-purpose or fire retardant polyesters suitable for marine use, and are to be catalyzed in strict accordance with manufacturers' recommendations.

1.1 Polyester Resins

Isophthalic polyester or orthophthalic polyester may be used. The former is often used for gel coat and outer ply lamination; the latter is an effective laminating resin.

1.3 Vinylester and Epoxy Resins

Epoxy resins cannot form a primary bond with polyester and vinylester resins. Epoxies can only be used either by themselves or in conjunction with fully cured polyester or vinylester resins.

1.5 Gel Coats

All gel coats are to be used in strict accordance with the manufacturers' recommendations. Where a gel coat is not used, details of the proposed water barrier are to be submitted for consideration.

1.7 Curing Systems

For polyester and vinylester resins, the level of catalyst and accelerator are to be as recommended by the manufacturer to ensure full polymerization of the resin. In general, the rate of gelation is to be controlled by the amount of catalyst accelerator added to the resin. The amount of catalyst is not to be less than 1% of the base resin, by weight.

1.9 Phenolic Resins

Phenolic resins having superior properties for fire resistance may not be suitable for structural applications. Where fire retardant additives to the resin system are used, the type and quantity are to be as recommended by the resin manufacturer. The results of independently tested fire retardant and fire restricting materials are to be submitted. All fire retardant systems are to be used in strict accordance with the resin manufacturer's recommendation.

1.11 Resin Properties

The properties of a resin are to be for the final form of the resin actually used in production with all additives and fillers included. The amount of silicon dioxide or other material added to provide thixotropy is to be the minimum necessary to resist flowing or draining. The following liquid and cured condition properties of resins are to be provided for the gel coat resin and laminating resin, and if different, for the skin coat:

- Liquid Properties (at 25°C)
 - Monomer Content %
 - Viscosity – Brookfield (Spindle No. & RPM) CPS
 - Thixotropic Index, Minimum
 - Specific Gravity
 - Flash Point, Closed Cup
 - Fillers (type and amount)
- Cure Characteristics (at 25°C)
 - Gel Time, Minutes (indicate initiator (catalyst) and activator (promoter) and %)
 - Gel to Peak, Minutes
 - Peak Exotherm
- Cured Properties for Resin Clear Casting
 - Barcol Hardness
 - Heat Deflection Temperature
 - Tensile Strength and Tensile Modulus
 - Tensile Elongation at Break, %
 - Flexural Strength & Modulus
 - Volume Shrinkage
 - Water Absorption
- Chemical analysis and shelf life.

For polyester resins, the tensile elongation at break is generally not to be less than 1.0% for laminating resins and is to be generally not less than 2.0% for gel coat resins. Elongation of other resins will be specifically considered.

1.13 Additives

Additives are only to be added by the resin manufacturer in accordance with the agreed procedure and tested accordingly. Where a resin contains an ingredient that can settle within the resin system, it is the builder's responsibility to ensure that the resin manufacturer's recommendations regarding mixing and conditioning are complied with prior to use.

1.15 Fillers

All fillers added by a builder are to be of the dispersed type. The amount of filler that may be added to a resin is to be recommended by the resin manufacturer and is not to significantly alter the viscosity of the resin nor is it to affect the overall strength properties of the laminate. Recommendations by the resin manufacturer to adopt amounts of fillers in excess of 13% by weight of the base resin will be subject to individual approval and testing. Pigments, thixotropes and fire retardant additives are to be considered as fillers in the calculation of total filler content. Fillers are to be carefully and thoroughly mixed into the base resin that is then to be allowed to stand to ensure that the entrapped air is released. The resin manufacturer's recommendations regarding the method of mixing are to be followed. Details of all fillers are to be submitted.

3 Reinforcing Materials

Fiber reinforcement includes E glass fiber, S or R glass, carbon and aramid (Kevlar) fibers. The use of hybrid reinforcing materials is also acceptable. To be considered a reinforced plastic, the properties of the cured laminate of resin and fiber must exceed those of the cured clear resin without fiber. Where coupling agents are used, they are to be of the silane type, and are to be compatible with the laminating resins.

5 Core Materials

Expected shear strengths of core materials are shown in 2-6-1/Table 1. Core materials other than those shown will be subject to special consideration. Polyester fiber or vinylester mat is not considered a lightweight structural core, and use will be subject to special consideration. Shear strength for use in the design is to be verified by test, as required in Section 2-6-5. Construction methods and procedures for core materials are to be in strict accordance with core manufacturer’s recommendations.

5.1 PVC Foam Cores

Foam cores are to be of the closed cell types and impervious to water, fuel and oils. Foam cores are to be compatible with the resin system and have good aging ability. Foam cores are to have good strength retention at 60°C (140°F). If the foam core is manufactured into formable sheets of small blocks, the open weave backing material and adhesive are to be compatible and soluble with the laminating resin. Where necessary, foam core materials are to be conditioned in accordance with the manufacturer’s recommendations. Conditioning at an elevated temperature in excess of that which may be experienced in service may be necessary to ensure the release of entrapped residual gaseous blowing agents from the cells of the foam core.

5.3 Balsa Wood

Balsa wood is to be end-grained. Balsa wood is to be treated chemically against fungal and insect attack and kiln-dried shortly after felling, and is to be sterilized and homogenized. Balsa wood is to have an average moisture content of 12%. If the balsa wood is manufactured into formable sheets of small blocks, the open weave backing material and adhesive are to be compatible and soluble, respectively, with the laminating resin.

5.5 Core Bonding Materials

Core bonding materials are to be used in accordance with the manufacturer’s instructions. The proposed core bonding to be used with the core material is to be indicated on the Material Data Sheet and the construction plans.

TABLE 1
Properties of Core Materials

Material	Density		Minimum Shear Strength		
	kg/m ³	lb/ft ³	N/mm ²	kgf/mm ²	psi
Balsa, end-grain	104	6.5	1.6 ⁽¹⁾	0.16 ⁽¹⁾	225 ⁽¹⁾
Balsa, end-grain	144	9	2.5 ⁽¹⁾	0.25 ⁽¹⁾	360 ⁽¹⁾
PVC, crosslinked	180	5	0.9	0.09	122
PVC, crosslinked	100	6.25	1.4	0.14	200
PVC, linear ⁽²⁾	80–96	5–6	1.2	0.12	170

Notes:

- 1 These values are for Ecuadorian balsa.
- 2 Caution is to be taken when linear PVC cores are used in areas that are susceptible to high temperatures because of their low heat distortion temperature.

7 Laminates

7.1 Basic Laminate

The basic laminate consists of an unsaturated general-purpose polyester resin and alternate plies of E-glass, fiberglass mat and fiberglass-woven roving fabricated by the contact or hand lay-up process. The minimum glass content of this laminate is 35% by weight.

7.3 Uni-directional Laminates

Lay-up details showing the thickness and weight of the plies are to be indicated on the drawings.

A sufficient balance of properties in the warp and fill directions is to be maintained to prevent laminate failure in any direction. The ratios of the verified minimum laminate strengths in the fill direction to those in the warp direction are to be not less than the following:

<i>Member</i>	<i>Fill Strength/Warp Strength</i>
Panel, aspect ratio = 1.0	0.80
Panel, aspect ratio > 2.0	0.61
Stiffening member	0.25

For panels with aspect ratios between 1.0 and 2.0, the ratios are to be obtained by interpolation.

The values of E_p/F , E_T/T and E_C/C in the fill direction are not to exceed the same ratios in the warp direction.

7.5 Bi-Directional Laminates

Lay-up details showing the thickness and weight of the plies are to be indicated on the drawings.

7.7 Sandwich Laminates

All core materials are to be effectively bonded to their laminated skins.

7.9 Mechanical Properties

The mechanical properties used in design for all laminates are to be verified by approved material tests. See Section 2-6-5.

2-6-1/Table 2 gives the average mechanical properties for various laminating materials. Thickness, strength and stiffness vary from the type of construction (hand lay-up, vacuum bagging, RTM or resin infusion) and the quality of the builder. These values are minimum for hand lay-up construction and are to be used for guidance only. For sandwich construction, the core to skin bond line is to be tested in tension (flatwise tension test, see 2-6-1/Table 1) to determine its integrity. The bondline is considered acceptable if failure occurs in the cored region of the sample or within the laminate skins. The properties to be used for a particular laminate are subject to verification by approved material tests, as required in Section 2-6-5.

7.11 Nonstructural Plies

Gel coats and skin coats of either fiber mat or fiber cloth weighing less than 30 grams per square meter (0.1 ounce per square foot) are considered to be nonstructural. They are not to be included when assessing laminate strength and stiffness.

7.13 Laminate Thickness

The average thicknesses given below are provided only as guidance to the designer for mat and woven plies laid-up separately. Thickness indicated on the submitted plans for use with the guide are to be verified by the Surveyor and approved material tests.

The cured resin-and-mat plies may be taken to have average thickness equal to 0.25 millimeters per 100 grams of mat in each square meter (0.03 inches per ounce of mat in each square foot) of the basic laminate. The cured resin-and-woven roving plies may be taken to have an average thickness equal to 0.12 millimeters per 100 grams of woven roving in each square meter (0.0016 inches per ounce of woven roving in each square yard) of the basic laminate.

For mat and woven roving laminates differing in glass content from the basic laminate, the average cured laminate thickness, t , (excluding nonstructural plies) can be obtained from the following equation:

$$t = \frac{Wk}{c} \left(\frac{305}{f_g} - 2.69 \right) \text{ mm (in.)}$$

where

- k = 0.35 mm (0.0138 inches)
 f_g = glass content, percentage by weight, of one ply of the mat and one ply of the woven-roving of the laminate to be used
 c = glass content per pair of composite fiberglass reinforcement of basic laminate,
 = 1272 g/m² (4.17 oz/ft²)
 W = total weight of fiberglass reinforcement of the laminate in g/m² (oz/ft²), of the laminate thickness, t

7.15 Plywood and Timber Members

Where plywood and timber members are to be used in structural applications and are to be laminated onto, or encapsulated within the laminate, the surface of the wood is to be suitably prepared and primed prior to laminating.

TABLE 2
FRP Laminate Properties

SI Units:

	<i>Basic Laminate</i> kgf/mm ²	<i>“S” Glass</i> kgf/mm ²	<i>Kevlar</i> kgf/mm ²	<i>Carbon</i> kgf/mm ²
Flexural Strength, F	17.5	45.9	23.5	51
Flexural Modulus, E_f	773	1835	2236	4500
Tensile Strength, T	12.6	36.4	39.4	43.4
Tensile Modulus, E_t	703	1920	2314	4500
Compressive Strength, C	11.9	30.5	14.4	30
Compressive Modulus, E_c	703	1828	2285	4430

MKS Units:

	<i>Basic Laminate</i> N/mm ²	<i>“S” Glass</i> N/mm ²	<i>Kevlar</i> N/mm ²	<i>Carbon</i> N/mm ²
Flexural Strength, F	172	450	230	500
Flexural Modulus, E_f	7580	18000	22000	43800
Tensile Strength, T	124	357	386	425
Tensile Modulus, E_t	6890	18800	22700	43800
Compressive Strength, C	117	299	142	284
Compressive Modulus, E_c	6890	18000	22500	43700

U.S. Customary Units:

	<i>Basic Laminate</i> psi	<i>“S” Glass</i> psi	<i>Kevlar</i> psi	<i>Carbon</i> psi
Flexural Strength, F	25000	65300	33400	72500
Flexural Modulus, E_f	1100000	2610000	3180000	6400000
Tensile Strength, T	18000	51800	56000	61700
Tensile Modulus, E_t	1000000	2730000	3290000	6400000
Compressive Strength, C	17000	43400	20500	41100
Compressive Modulus, E_c	1000000	2600000	3250000	6300000

9 Adhesives

9.1 General

Adhesives for structural applications are to be used in accordance with the manufacturer's recommendations. The details of all structural adhesives are to be specified on the Material Data Sheet and on the construction plans submitted. Details concerning the handling, mixing and application of adhesives are to form part of the Builders Process Instruction. Particular attention is to be given to the surface preparation and cleanliness of the surfaces to be bonded. Where excessive unevenness of the faying surfaces exists, a suitable gap-filling adhesive is to be used or local undulations removed by the application of additional reinforcements. The Builder Process Description is to identify the level of training required for personnel involved in the application of structural adhesives.

9.3 Requirements for Structural Application

For adhesive materials to be acceptable for use in structural applications, they are to comply with the following requirements:

- i)* The minimum shear strength of the adhesive is to be between 6.9 N/mm^2 (1000 psi) and 10 N/mm^2 (1500 psi). This shear strength is to be achieved in temperatures ranging from ambient to 49°C (120°F). The testing is to be performed to ASTM D1002 or ASTM D3165 using FRP substrates. All failures of test samples are to be either cohesive or fiber tear.
- ii)* The adhesive is to be tested in fatigue using ASTM D3166 (note: the test substrates may be metallic). The test is to be conducted at 50% of the ultimate tensile strength and is to last for a minimum of one million cycles at 30 Hz.
- iii)* The process for the application of the adhesive is to be submitted for review and is to include the maximum bondline thickness, nondestructive testing methods and maximum creep.
- iv)* The elastic modulus of the adhesive is to be considerably less than that of the FRP skin to which it is being adhered
- v)* The strain of failure ratio of the adhesive is to be much larger than the surrounding structure.
- vi)* The mechanical properties of the adhesive are achieved rapidly, such that the use of screws or bolts will not be necessary to hold the substrates together while the adhesive cures.
- vii)* The adhesive is to be compatible with the lamination resin.

PART

2

CHAPTER 6 Materials for Hull Construction – Fiber Reinforced Plastics (FRP)

SECTION 2 Fabrication

1 General

The use of fabricating procedures differing from those given below will be specially considered.

3 Fabrication Procedures

3.1 General

The laminate is to be lay-up by one of the following methods:

- Hand layup or contact process
- Vacuum Bagging
- Resin Impregnation
- Resin Transfer Molding (RTM)
- Resin Infusion
- Pre-preg

3.3 Laminate Layup

A layer or ply of reinforcing material may consist of a number of pieces. The pieces are to be lapped along their edges and ends. The width of each lap is to be not less than 50 mm (2 in.). Unless otherwise specifically approved, no laps in the various plies of a laminate are to be closer than 100 mm (4 in.) to each other.

Transitions in laminate thickness are to be tapered over a length not less than three times the thickness of the thicker laminate. A gradual transition in fiber reinforcement is to be provided between bidirectional and unidirectional laminates.

3.5 Sandwich Panel Layup

Sandwich panels may be laminated with cores that either are effective in resisting bending; tension, compression, shear and deflection (e.g., plywood) or are essentially ineffective in resisting bending, tension, compression and deflection, but are capable of carrying shear loads, (e.g., balsa wood and plastic foam).

All cores are to be effectively bonded to the skins in accordance with the manufacturer's recommendation (e.g., vacuum bag techniques with an approved bedding putty). Joints in core materials are to be scarphed and bonded or connected by similar effective means.

Where sandwich panels with ineffective cores are used in way of mechanically connected structures, gears and equipment, a core effective in resisting bearing, shear, flexure and compression is to be inserted. The inserts are to be bonded to the skins or faces of the sandwich and to the adjacent core.

The ply of skin laminate in contact with each face of a core material is to be chopped-strand mat. The mat is to be thoroughly impregnated with resin and the core is to be coated with resin before lay-up. For foam cores, the resin is to be applied and sufficiently rolled to ensure that all voids are filled, and the coat of resin for wood cores should be substantial enough to seal the grain of the wood.

3.7 Secondary Bonds

In general, secondary bonds should only be used when a primary bond cannot be achieved. Where ever possible, peel-ply should be applied to the outer layer of the surface requiring the secondary bond. When preparing for a secondary bond, the following criteria along with the manufacturer's recommendations should be adhered to:

- i)* The area is to be clean and free from all foreign particles such as wax, grease, dirt and dust.
- ii)* When grinding is required, the grinding is not to damage any of the structural glass fibers, thus weakening the laminate, especially in highly stressed areas.

In general, the first ply of the secondary lay-up is to be chopped-strand mat. The final ply of laminate along the bond line of the cured laminate is preferably to be chopped-strand mat.

Where methods other than conventional secondary bonding are proposed, the shipyard is to demonstrate that the proposed method is equivalent in strength to a conventional secondary bond.

PART

2

CHAPTER 6 Materials for Hull Construction – Fiber Reinforced Plastics (FRP)

SECTION 3 Building Process Description

1 General

The building process description is to be submitted for review by the builder before construction starts. Information on the following items is to be included.

- i)* Description of construction facilities, including environmental control and material storage and handling.
- ii)* Specifications for resins, reinforcing products and core materials including the manufacturer's recommendations.
- iii)* Lay-up procedures, including type, orientation of reinforcements, sequence, resin mixing methods and resin pot-life limits.
- iv)* Secondary bonding procedures.
- v)* Inspection and quality control systems
- vi)* Laminate properties derived from destructive qualification testing including sample check sheets, forms and guides.

3 Building Facilities

3.1 Material Storage Premises

The premises are to be equipped and arranged so that the material manufacturer's recommendations for storage and handling can be followed:

3.1.1

Premises are to be enclosed, protected from the sun, clean, dry, ventilated as necessary and sufficiently free of dust so that materials are not contaminated or degraded. Materials are to remain sealed in storage as recommended by the manufacturer.

3.1.2

Before use, fiber reinforcements are to be stored for at least 48 hours at a temperature and humidity similar to that of the laminating premises.

3.1.3

Resins, catalysts, hardeners and accelerators are to be stored in a well-ventilated space at temperatures recommended by the manufacturer. The storage period is not to exceed the shelf lives. Fillers and additives are to be stored in closed containers impervious to humidity and dust. Resin tanks are to be arranged so that they can be stirred at the frequency and time recommended by the manufacturer.

3.1.4

Core materials are to be stored in a dry space and protected against damage; they are to be contained in their protective packaging until immediately prior to use.

3.1.5

Materials that may be considered hazardous to each other are to be stored separately. Catalyst is to be stored in a cool, dry location away from manufacturing facility in accordance with fire and insurance codes.

3.3 Mold Construction

Molds are to be constructed to the following criteria:

3.3.1

Molds are to be constructed of a suitable material and are to be adequately stiffened to maintain their overall shape and fairness of form.

3.3.2

The materials used in the construction of molds are not to affect the resin cure.

3.3.3

The finish on a mold is to be such that the moldings produced are suitable for the purpose intended. The resultant aesthetic appearance of the molding is not part of ABS Survey and approval.

3.3.4

Where multiple section molds are used, the sections are to be carefully aligned to the attending Surveyor's satisfaction prior to molding. Mismatch between mold sections is to be avoided.

3.3.5

The release agent (e.g., mold wax, etc.) is to be of a type recommended by the resin manufacturer and is not to affect the cure of the resin.

3.3.6

Prior to use, all molds are to be conditioned to the workshop temperature.

3.3.7

Lifting arrangements are to be designed such that moldings are subjected to minimal distortion and unnecessary stressing. Moldings are to be adequately supported to avoid distortion during final cure.

3.5 Laminating Premises

Premises are to be arranged and equipped so that the material manufacturer's recommendations and builder's standards for handling, laminating and curing can be followed:

3.5.1

Premises are to be fully enclosed, dry, clean, shaded from the sun and adequately ventilated to remove fumes, overspray and dust from the molds and laminating area and properly and adequately lighted. Precautions are to be taken to avoid any effects on the resin cure due to direct sunlight or artificial lighting.

3.5.2

Temperature is to be maintained adequately constant at a temperature between 16°C and 32°C (60°F and 90°F). The humidity is to be kept adequately constant to prevent condensation and is not to exceed 80%. Where spray molding is taking place, the humidity is not to be less than 40%. Temperature and humidity are to be within limits recommended by the manufacturer of the materials. Departures from the foregoing will be considered, provided the temperatures and humidity are within the limits recommended by the manufacturer and are reviewed by ABS prior to laminating.

3.5.3

The laminating temperature in the premises is to be attained at least 24 hours before commencement of lamination, and is to be maintainable, regardless of the outdoor temperature.

3.5.4

Sufficient temperature and humidity monitoring equipment is to be provided, and detailed records are to be kept in accordance with the Quality Assurance system.

3.5.5

Laminating areas are to be remote from operations creating dust.

3.5.6

Scaffolding is to be provided, where necessary, to avoid standing on cores or on laminated surfaces. Such arrangements are to conform to the National Authority requirements and are not, in general, to be connected to the molding or impinge on the mold surface.

3.5.7

It is the responsibility of the builder to ensure that the ventilation and working conditions, together with discharges into the atmosphere, are such that levels of substances are within the limits specified in any pertinent National or International legislation.

3.7 Equipment

All equipment is to be well maintained and operated to the specifications underlined by the equipment manufacturer's recommendations and the following guidelines:

3.7.1

Production equipment, hose connections, gauge faces, spray guns, meters and pumps are to be kept clean and properly serviced.

3.7.2

Floors and work tables are to be regularly cleaned and reasonably free of accumulation of resin and reinforcing materials.

3.7.3

Compressed air for air operated equipment is to be clean, dry and free from contaminants such as oil, moisture or dirt. The system should include traps that are cleaned and serviced frequently.

3.7.4

The catalyst injection accelerator of the spray gun is to introduce the catalyst into the resin or gel coat in a precise ratio and to result in a thoroughly homogeneous mixture. This accelerator is to be checked and calibrated frequently.

3.7.5

Chopper guns are to be maintained properly adjusted to ensure the desired fiber to resin ratio, fiber length and fiber distribution.

3.7.6

Resin delivery systems, both portable and fixed, are to be readily accessible for service and maintenance, including the cleaning of lines to prevent contamination.

3.7.7

For spray laminating, the weight of resin and reinforcement used is to be continuously monitored to check the glass/resin ratio. Samples are also to be taken on a regular basis to validate the calibration equipment.

3.7.8

All measuring equipment is to be certified and suitable for the quantity of material being measured. Valid certificates of calibration are to form part of the quality control documentation.

5 Specifications and Data Sheets for Materials

Material specifications and data sheets are to be provided to the builders by the material manufacturers. In general, these data sheets are to include the cured, mechanical properties of sample laminates as guidance to the designer. The material specification and data sheets are to also include information indicating the safe use and treatment of operators in the case of contamination.

5.1 Resins, Gel Coats, Catalysts, Accelerators, Hardeners and Other Additives

The specifications are to indicate the contents of the resin and gel coats, type and amount of catalyst, accelerators, hardeners and other additives, as well as recommendations for storage, handling and use.

Data sheets are to provide liquid and cured form physical and mechanical properties, as well as curing characteristics at a specified temperature indicating the gel time variation with air temperature and amount of catalyst and accelerator, or amount of hardener. Cured mechanical properties are to be given for un-reinforced resin. Batch data sheets are to be supplied with each delivery, indicating the physical and mechanical properties of the particular delivered batch. All resins are to be used within 90 days of their specified “batch date,” unless acceptable by the manufacturer of the material. Batch data sheets are to be retained.

5.3 Reinforcing Materials

For reinforcing material, the specification is to indicate the fiber type and form, weave, fiber orientation, weight, physical data and mechanical properties.

Detailed storage records are to be maintained as part of the quality control documentation.

5.5 Core Materials

Core material specifications are to indicate the material specification number, material type, density and recommendations for storage, handling and use.

7 Receiving Materials

7.1 Resins, Gel Coats, Catalysts, Accelerators, Hardeners and Other Additives

The builder is to have a range of acceptance criteria for properties. The builder is to sample and test each batch to verify properties. Cured samples should be retained for future reference in the event of subsequent problems such as rapid yellowing, sun blistering and print through. All incoming raw materials are to be tested and inspected on receipt. Following testing, the drums or containers are to be labeled “Approved” or “Rejected.” “Rejected” material is to be immediately returned to the manufacturer. See Section 2-6-5.

7.3 Reinforcing Materials

Testing on incoming materials should include a weight check and a visual inspection of a sample of the material for its physical condition. Batch data sheets are to be retained.

7.5 Core Materials

Check tests on density and moisture content for core materials are required. Batch data sheets are to be retained.

9 Laminating Procedure

This laminating procedure is for a standard hand lay-up technique. Different laminating techniques will be specially considered.

9.1 Start-up

Before laminating, the following items are to be checked and complied with:

9.1.1

Clean, dry, contaminant free air is delivered to equipment.

9.1.2

All materials are at laminating premise temperature.

9.1.3

Resins and gel coats are to be agitated to ensure a uniform mix. Manufacturer's recommendations are to be adhered to, do not over agitate. Curing agents, fillers and pigments are to be added in strict accordance with the resin manufacturer's recommendations.

9.1.4

The condition of the resin, gel coat and catalyst delivery system is to be checked to ensure proper pump operations, tips are clean, clear and in good condition, seals and lines are free of leaks and that the filters are clean.

9.1.5

The equipment is to be calibrated in accordance with the equipment manufacturer's instructions. Set delivery rates, ratios and mix to the material manufacturer's instructions. Check the gel and cure times to verify calibration.

9.1.6

Record temperature, flow rates and catalyst ratios and maintain.

9.1.7

Catalyst amount is to be determined in accordance with the manufacturer's instructions.

9.1.8

Inspect the mold to ensure that there is adequate mold release agent, that the surface is dry and clean and that the mold temperature is the same as the laminating premise temperature.

9.3 Application of Gel Coat

9.3.1

Apply the catalyzed gel coat, typically using multiple uniform passes of six to eight mils to build up a uniform wet thickness of 25 to 30 mils. Recommended time between passes is 15 to 30 seconds; consult the manufacturer for optimum time and for optimum gel coat thickness.

9.3.2

Commence lamination of skin coat as soon as adequate film cure has occurred in accordance with gel coat manufacturer's specification.

9.5 Lamination of Skin Coat

9.5.1

Exposed surface of gel coat is to be kept clean, free of dust and contaminants.

9.5.2

Wet film of catalyzed resin is applied by pouring, brushing or spraying to the entire gel coat surface. Apply at least 300 g/m² (1 oz/ft²) chopped strand or other skin coat, as indicated on the approved plans, into wet resin and apply sufficient additional resin to complete wet-out of glass, i.e., resin encirclement of each individual fiber or complete impregnation of the mat, roving or cloth.

9.5.3

Roll-out skin coat to ensure saturation of fibers and elimination of air and voids in the skin coat. The consolidation is to be done with gentle rolling and with care not to damage the gel coat.

9.7 Main Lamination – Single Skin

9.7.1

Laminating is to be carried out by skilled workers trained and qualified to the level required by the Quality Control Plan.

9.7.2

Carry out lay-up in accordance with the lay-up schedule on the approved plans giving particular attention to type of reinforcing ply and their orientation.

9.7.3

Wet film of catalyzed resin is applied by pouring, brushing or spraying to the entire skin-coated surface. Apply next reinforcing ply as required, and apply it to sufficient resin to completely saturate the glass fibers. Carefully roll-out the laminate to remove air pockets and void spaces.

9.7.4

Continue as indicated in the lay-up schedule. Time between plies is to be in accordance with the material manufacturer's recommendations.

9.7.5

The approved laminate schedule is to be carefully followed with respect to the particular ply type, weight and orientation. Ply overlaps along edges and at ends and ply staggering are to be in accordance with the approved plan.

9.7.6

During lay-up, guidance on gel time is to be strictly followed with regard to laminating premise temperature and the amount of catalyst. The gelation time is to be suitable for the proposed application such that full wet-out of the reinforcement can be obtained without unnecessary drainage on vertical surfaces or excessive loss of the monomer.

9.7.7

The degree of laminate cure is established by the Barcol Hardness Test. The hardness meter is to be regularly checked for calibration during use. A value of 40 or more indicates a satisfactory degree of cure for polyester resin. Lesser values may be used for vinylester and epoxy resins. These are to be in accordance with the manufacturer's recommendations.

9.7.8

Excessive exothermic heat generation caused by thick laminate construction is to be avoided. Where thick laminates are to be laid, the builder is to demonstrate to the Surveyor's satisfaction that the number of plies can be laid wet on wet and that the resultant temperature during the cure cycle does not have any adverse effect on the mechanical properties of the cured laminate.

9.7.9

Laminating is to be carried out in a sequence and documented in the quality control procedure for the particular resin system. Similarly, the time lapse between the forming and bonding of structural members is to be kept within the limits recommended by the resin manufacturer. Where this is not practicable, the surface of the laminate is to be prepared to improve the bond in accordance with the resin manufacturer's instructions.

9.7.10

Particular attention is to be given to localized thinning of the laminate in way of chines, coamings, knuckles and openings. Further deposition may be required in such areas to compensate for any reduction in thickness. Alternatively, layers of other equivalent reinforcements may be laid to achieve the required local thickness.

9.7.11

The exposed edges of all openings cut in single skin laminate panels are to be suitably sealed. Where such edges are in wet spaces or under water, the edges of such openings are to have rounded edges and are to be sealed by two plies of 450 g/m² (1.5 oz/ft²) chopped strand mat (or equivalent) reinforcement.

9.9 Main Lamination – Sandwich Laminate

9.9.1

For sandwich laminates, where applicable, single skin requirements are to be adhered to.

9.9.2

The ply before the core is to be chopped strand mat. Mat is to be thoroughly wet-out with a generous application of resin. Alternatively, core manufacturer's putty or compound may be used. Core is to be laid-up in strict accordance with the core manufacturer's instructions and approved plans. A generous coat of resin or putty, etc. is to be applied to the core and subsequent ply, generally chopped strand mat, applied and thoroughly wet-out and rolled out. The core is to be vacuum bagged to the skins. Where it is not practicable, alternative lamination will be considered.

9.9.3

Where the core material is to be laid onto a pre-molded skin, it is to be laid as soon as practicable after the laminate cure has passed the exothermic stage.

9.9.4

Where the core is applied to a laminated surface, particular care is to be taken to ensure that a uniform bond is obtained. Where a core is to be applied to an uneven surface, additional building up of the surface or contouring of the core is required.

9.9.5

Where other than epoxy resins are being used, the reinforcement against either side of the core is to be of the chopped strand mat type. No additional flow coating is to be applied to the foam core prior to laminating.

9.9.6

Prior to bonding, the core is to be cleaned and primed (sealed) in accordance with the manufacturer's recommendations. The primer is to be allowed to cure and is not to inhibit the subsequent cure of the materials contained within the manufacturer's recommended bond process. The primer is to seal the panels, including all surfaces between the blocks of contoured material, without completely filling the surface cells.

9.9.7

Where panels of rigid core materials are to be used, the vacuum bagging techniques are to be adopted. The core is to be prepared by providing "breather" holes to ensure efficient removal of air under the core. Bonding paste is to be visible at such breather holes after vacuum bagging. The number and pitch of such "breather" holes is to be in accordance with the core manufacturer's application procedure and any specific requirements of the core bonding paste manufacturer.

9.9.8

Thermoforming of core material is to be carried out with the core manufacturer's recommendations. Maximum temperature limits are to be observed.

9.9.9

Where panels of controllable core material are to be used, it is necessary to ensure that the core is cut/scored through the entire thickness such that the panels will conform to the desired shape of the molding. The builder is to demonstrate that the quantity of bonding material indicated in the core manufacturer's application procedure is sufficient to penetrate the full depths of the core between the blocks. It is recommended that grid-scored panels using a carrier scrim cloth are adopted.

9.9.10

In all application procedures, cured excess bonding material is to be removed and the panel cleaned and primed prior to the lamination of the final sandwich skin.

9.9.11

Inserts in sandwich laminates are to be of a material capable of resisting crushing. Inserts are to be well bonded to the core material and to the laminate skins in strict accordance with the approved plans.

9.9.12

The level of vacuum applied for initial consolidation and during the cure period is not to be higher than that recommended by the relevant manufacturer of the materials being used, to avoid the possibility of evaporative boiling and excessive loss of monomer.

9.9.13

Exposed edges of openings cut in sandwich panels are to be suitably sealed. The cut edges are, in general, to be sealed with a weight of reinforcement not less than that required for the outer skin of the sandwich. Where other than an epoxy resin system is used, the first layer of such reinforcement is to be chopped strand mat with a weight not exceeding 450 g/m² (1.5 oz/ft²).

9.9.14

Scored core material should be avoided whenever possible. However, when necessary, only single cut core material should be used in all external panels. When scored core material is used, the scores are to be properly filled with the bedding putty. The layer of bedding putty between the core material and the FRP skins should be between 0.5 mm and 2 mm (0.02 in. and 0.08 in.) thick.

9.11 Release and Curing

9.11.1

After completion of the lay-up, the molding is to be left in the mold for a period to allow the resin to cure before being removed. This period is not to be less than 12 hours or that recommended by the resin manufacturer.

9.11.2

Care is to be exercised during removal from the mold to ensure that the hull, deck and other large assemblies are adequately braced and supported to avoid damage and to maintain the form of the molding.

9.11.3

Where female molds are adopted, all primary stiffening and transverse bulkheads are to be installed prior to the removal from the mold unless agreed otherwise.

9.11.4

Moldings are not to be stored outside of the workshop environment until they have attained the stage of cure recommended by the resin manufacturer for that particular resin. Provision is to be made for moldings to be protected against adverse weather conditions.

9.11.5

Moldings are, in general, to be stabilized in the molding environment for at least 24 hours, or that recommended by the resin manufacturer, before the application of any special cure treatment, details of which are to be submitted for approval.

9.13 Secondary Bonding

9.13.1

Laminating is to proceed as a continuous process, as far as practicable, with the minimum of delay between successive plies. Where a secondary bond is to be made, it is to be carried out with the resin manufacturer's recommendation, details of which are to be incorporated into the builder's quality assurance plan.

9.13.2

Internal stiffening members, internal structural bulkheads, etc. are generally secondary bonded to the hull. Secondary bonding is the application of a resin wet ply to an already fully cured surface.

9.13.3

The cured surface is to be sanded and thoroughly cleaned and dry. A generous coat of resin is to be applied to the cured surface and the first ply laid-on and further resin applied. The first ply is generally chopped strand mat. An alternative method is to use a peel ply on the cured laminate, which is to be removed and the laminate is to be lightly abraded prior to the secondary bond.

9.13.4

The overlap of the resin wet plies to the cured laminate are to be in accordance with the approved plans.

11 Inspection

11.1 General

Inspection is to be carried out by the builders and Surveyors, as indicated and approved in the building process description and building quality control manual. A constant visual inspection of the laminating process is to be maintained by the builder. If improper curing or blistering of the laminate is observed, immediate remedial action is to be taken. Inspections of the following are to be carried out:

- i)* Check the mold to ensure it is clean and releasing agent is properly applied.
- ii)* Gel coat, check thickness, uniformity and application and cure before applying laminating resin first layer of reinforcement.
- iii)* Check resin formulation and mixing. Check and record amounts of base resin, catalysts, hardeners, accelerators, additives and fillers.
- iv)* Check that reinforcements are uniformly impregnated and well wet-out, and that lay-up is in accordance with approved drawings and the approved standards of overlaps are complied with. All variation in materials should be brought to the attention of the appropriate ABS Technical Department.
- v)* Check and record resin/fiber ratios.
- vi)* Check that curing is occurring as specified. Immediate remedial action is to be taken when improper curing or blistering is noted.
- vii)* Visual overall inspection of completed lay-up for defects that can be corrected before release from the mold. The laminated parts are to be free of open voids, pits, cracks or protruding fibers.
- viii)* Check and record hardness of cured hull prior to release from mold.
- ix)* The ambient temperature, humidity and gel time is to be monitored and recorded.

11.3 Voids

Excessive void content can reduce the overall strength of the laminate, and therefore, the laminate is to be inspected for the following:

- i)* There are to be no voids extending through more than one ply of laminate.
- ii)* There are to be no voids larger than 12 mm (0.50 in.) in their greatest dimension.
- iii)* There are to be no voids larger than 3 mm (0.125 in.) on each ply in any 150 mm × 150 mm (6 in. × 6 in.) area, with a maximum of six (6) total voids in this area.
- iv)* There are to be no more than three (3) voids larger than 3 mm (0.125 in.) on each ply in any 300 mm × 300 mm (12 in. × 12 in.) area, with a maximum of twenty (20) total voids in this area.

Note that interconnected voids are to be considered a single void, and spaces occupied by foreign matter in the laminate are to be considered as voids.

13 Faults

13.1 General

All faults are to be classified according to their severity and recorded, together with the remedial action taken, under the requirements of the Quality Assurance systems.

13.3 Production Faults

Production faults are to be brought to the attention of the attending Surveyor and a rectification system is to be agreed upon.

PART

2

CHAPTER 6 Materials for Hull Construction – Fiber Reinforced Plastics (FRP)

SECTION 4 Quality Control

1 Application

A quality assurance system is to be set up in association with the building process description. The objective of the system is to measure and record compliance with approved plans and the building process description. Quality control records are to be carefully kept, and are to be available at all times for review and routine verification by the ABS Surveyor. Compliance with the quality assurance system is required, in general, for craft that are obtaining ABS classification.

3 Definitions

3.1 Hull Construction

Hull construction consists of construction of the hull, deck, deckhouse and all other structure that affects the structural, weathertight and watertight integrity of the craft. Included are windows, doors, hatches, rudders, skegs and keels.

3.3 Quality Assurance Standard

The quality assurance requirements of ABS for the hull construction of small craft.

3.5 Quality Assurance

All activities and procedures concerned with the attaining of quality, including records and documents to verify attainment.

3.7 Quality Assurance System

The organization indicating responsibilities, activities, resources and events that provide the procedures from which data and records originate to verify the builder's capability to comply with quality requirements. It includes the building process description.

3.9 Building Process Description

A description of the building process, covering building facilities, material receiving procedures, laminating process, inspection and testing. Monitoring and recording of the building process description implements quality control.

3.11 Quality Control

The operational means and functions used to measure and regulate the quality of construction to the required standards.

3.13 Inspection

The process of measuring, examining, testing and comparing an item with the approved plans, approved building process and approved builder's standards.

3.15 Assessment

The initial inspection of the quality system at the builder's facilities to verify that all requirements are met and that the facilities are in accordance with the approved building process description and quality control procedures.

3.17 Audit

Verification that the building process and quality control process continue to be as effectively maintained as they were at the initial assessment.

3.19 System Monitoring

The checking by ABS Surveyors on a regular basis the processes, activities and necessary documentation to verify that the builder's quality system continues to be effectively carried out in accordance with the ABS quality assurance standard.

5 Design

5.1 Plan Review

The plans showing scantlings and arrangements and details of materials, building process description and quality assurance manual, as listed below, are to be submitted for review prior to start of production. All review amendments are to be included on the working plans.

5.3 Revisions

Any revisions made after approval are to be submitted to the attending Surveyor, who, at his discretion, may agree to the revision or require the plans to be resubmitted for approval. Where the Surveyor agrees to the revision, he is to provide the Technical Office responsible for plan approval with the details.

7 Building Process Description – Quality Control

A building process description is to be submitted for review. It is to cover in detail the building facilities, receipt of materials process, manufacture, inspection and testing. The relevant stages in the building process description are to be monitored and recorded as given in the quality assurance manual. It is to be agreed upon at which stages the Surveyor will carry out quality control monitoring and direct inspection. Direct inspection will include, but will not be limited to, final inspection on completion of construction.

9 Certification of Quality Assurance

At the request of the builder, ABS will carry out plan approval of the craft to be constructed and review of the Building Process Description and Quality Assurance Manual. On satisfactory completion of this and subsequent inspection by an ABS Surveyor to verify the building process and quality assurance system are in accordance with the reviewed documents, a Quality Assurance Certificate will be issued.

The certificate is valid for one year and will be reissued each year, subject to a satisfactory audit.

All information and data submitted by a builder for approval or review under the ABS Quality Assurance program will be treated with strictest confidence and will not be shown to or discussed with any third party without the written consent of the builder.

Builders receiving ABS Quality Assurance Certificates will be published by ABS, together with information on whether the craft are receiving classification or type approval.

11 Documentation of Quality Assurance System

The builder is to establish, document and maintain an effective quality assurance system to ensure and verify that the material, processes and procedures used comply with the applicable requirements.

This documentation is to be in the form of a quality assurance manual that provides the policies, and fully details procedures adopted to comply with the applicable requirements.

13 Personnel

A representative of the builder will be named to have the necessary authority and responsibility to ensure the requirements of this standard are complied with. Unless specifically approved otherwise, the quality assurance representative is to have no other duties or functions. This representative is to have the authority to stop production in the event of a serious quality problem.

The builder is to have an adequately staffed quality control group whose duties are carried out free of production priorities. This group will generally be supervised by the builder's quality assurance representative.

Other staff whose duties affect quality, including production management, are to have specified responsibility and authority to identify, control and assess quality. In process, inspections may be done by production staff, provided it is checked by the builder's quality control group representative on staff.

15 Internal Audit

Internal audits of the quality assurance system in all production areas and other areas concerned with product quality, as given in this standard, are to be carried out under the supervision of the builder's quality assurance representative. The audits are to be at an agreed frequency and the results are to be evaluated at a management review meeting attended by the builder's quality assurance representative and the production and testing management.

17 Documentation

The approved quality assurance manual, building process description, approved plans, material specifications, material bunch data sheets, completed quality control forms, material sample and test results are to be prepared and maintained readily available for inspection by the Surveyor.

19 Purchase

19.1

Materials and components incorporated into the hull construction that affect quality are to be obtained from recognized manufacturers and suppliers. Recognition may be on the following:

- i)* Documented records of previous satisfaction in supply.
- ii)* Approval by a recognized independent organization to a suitable quality assurance standard.
- iii)* Batch sample inspection and testing against batch data sheets and approval by ABS.
- iv)* Satisfactory assessment and evaluation of the manufacturer's/supplier's capability or quality assurance system at the manufacturer's/supplier's plant by the builder's quality assurance representative.

19.3

Records of manufacturers and suppliers are to be kept to monitor their performance. Those with a poor record are to be considered for replacement.

19.5

Purchase requisitions are to contain all of the necessary technical specification details.

19.7

Purchase orders are to be precise and clear, giving revision status of all referenced documents, standards, etc. and are to include any requirements for certification. Purchase orders are to be reviewed for accuracy prior to issue.

21 Material Receipt, Inspection and Storage

21.1

The material is to be kept separate prior to receiving inspection.

21.3

All materials are to be confirmed as identifiable to a purchase order, and that they are in a satisfactory condition, having no damage or contamination. Data batch sheets are to be provided with each delivery, and where required, certificates of conformity. Batch sample test may be required.

21.5

The temperature, humidity and cleanliness of the storage spaces for resin system materials, fiber reinforcing materials and core materials are to be monitored and recorded at a suitable frequency.

21.7

Materials with a limited shelf life are to be used before the expiration date and in full compliance with the manufacturer's recommendations.

21.9

Where the ambient temperature of the production area differs from that of the storage area, and the material performance is affected by this temperature difference, the material is to be placed in the production area in time to allow the necessary temperature change to occur before the material is used.

21.11

All material is to be fully identifiable in storage and is to be maintained from issue to use in production.

21.13

All material known or thought to be nonconforming is to be segregated from acceptable material.

23 Production

23.1

The necessary plans and other instructions are to be available to the manufacturing staff in all work areas. Instructions are to include control of equipment and method of working.

23.3

All material, parts, hulls and decks during construction are to be specifically identified and are to be traceable to the applicable plans, work instructions, etc.

23.5

Work during the manufacturing stages is to be carried out strictly in accordance with the applicable building process description and monitored and recorded on documents that are part of the building process description. The builder's staff member responsible for each stage is to sign to accept responsibility as soon as the stage is satisfactorily completed.

23.7

Production areas are to have the means of controlling the ambient temperature and humidity. The respective values are to be monitored and recorded at regular intervals. The working areas are also to be kept adequately clean and dust free.

23.9

Materials are to be taken from the stores in sufficient quantities so that they can be processed without delay. Materials waiting to be used are to be kept in conditions that will not lead to contamination, such as moisture absorption or deterioration.

23.11

The production staff is to have ready access to instructions on mold preparation, resin mixing, laminating, curing and release processes.

23.13

The time of application of gel coat, laminating and other time sensitive processes is to be monitored and recorded.

23.15

All equipment and tools in the laminating process such as gel coat and resin application systems, catalyst mixing systems, spray lay-up equipment, compressed air systems, etc. are to be maintained, serviced and calibrated at suitable intervals to ensure that they are in good working order.

23.17

The list of personnel trained in the laminating processes is to be readily available.

25 Production Inspections and Tests

Inspection and tests are to be carried out at the appropriate stages of manufacture in accordance with the building process description. The acceptance/rejection criteria are also to be in accordance with the building process description. Inspections and tests are to be carried out and recorded by authorized personnel and each inspection and test is to be signed for when satisfactorily completed. Subject to prior agreement, certain inspections may be carried out by production personnel, provided there is a system for monitoring by the quality control staff.

27 Final Inspection

Final inspection of each completed hull is to be carried out by the quality control staff. It is to include verification that the construction processes and inspections have been completed satisfactorily, documented and that no outstanding nonconforming items remain.

29 Nonconforming Materials and Components

29.1

All materials and components considered to be nonconforming are to be clearly labeled as such and kept separated from accepted materials.

29.3

There is to be a system of recording a nonconformance, for documenting the authorized corrective measures and for confirmation, where applicable, that the nonconformance has been eliminated by corrective measures.

31 Corrective Action

31.1

Guarantee claims and other customer complaints are to be recorded, together with the agreed method of rectification.

31.3

Records of guarantee claims and customer complaints, cases of nonconformance and inspection test results are to be analyzed at suitable intervals to detect trends and introduce corrective measures to reduce the probability of any recurrence.

31.5

Corrective actions are to be kept under surveillance until their effectiveness and suitability are proven satisfactory by experience.

33 Calibration and Maintenance of Equipment

33.1

Production and inspection equipment is to be calibrated and maintained to ensure the procedures and criteria for workmanship and inspection can be carried out with the necessary precision and quality. Whenever available, the manufacturers' calibrations are to be used.

33.3

A list of all such equipment is to be maintained with each item specifically identified and its required calibration/maintenance marked on the item.

33.5

The calibration/maintenance interval and the method and accuracy of the calibration/maintenance of each type of equipment are to be established.

33.7

Records of the calibration/maintenance process are to be maintained and are to include details of any adjustment or repairs.

33.9

Calibration is to be carried out against master instruments of known accuracy based on national or international standards or in accordance with the manufacturer's instructions.

33.11

The interval, method and results of calibration/maintenance are to be reviewed at internal audits.

35 Training

The necessary basic training, qualifications or experience for, as a minimum, the quality assurance, inspection and test personnel, and those performing the laminating and forming processes, calibration, maintenance and internal or external auditing/assessing, are to be prescribed by the builder.

37 Records

37.1

The builder is to develop and maintain records that show achievement of the required quality and the effective operation of the quality system. The following categories of documents, as a minimum, are to be retained as records after their use:

37.1.1

Superseded versions of the quality assurance manual, documented procedures, generally applicable work instructions and workmanship standards, internally produced standards, accept/reject criteria and representative samples, procedure approval tests and lists of recognized suppliers.

37.1.2

Working drawings and their revision history, copies of purchase orders, records of incoming, in-process and final inspections and tests, certificates of conformity for the raw materials used, records of temperature and humidity, completed nonconformance reports, guarantee claims, customer complaints, training records, internal audit reports, corrective action analysis and minutes of management review meetings.

37.3

All records are to be kept for a defined period of time. Product related records are to be kept for a statutory period of time.

37.5

All records are to be efficiently collated, held in secure storage and systematically identified and indexed to enable retrieval.

PART

2

CHAPTER **6** **Materials for Hull Construction – Fiber Reinforced Plastics (FRP)**

SECTION **5** **Testing**

1 **Gel Time**

The builder is to establish and implement a resin gel-time control system for the gel-time desired in production. This gel time is to be within the gel time upper and lower limits recommended by the resin manufacturer. Resin mixes are to be monitored and recorded to assure proper gel times. During layup, the temperature and humidity in the laminating area is to be recorded at regular intervals. The catalyst and gel time are to be adjusted to suit any changing conditions.

3 **Barcol Hardness**

Prior to removal from the mold, the laminate is to be checked with a Barcol hardness tester at a suitable number of locations to determine the degree of cure. The Barcol hardness number of the cured laminate measured on the surface without the gel coat is to be not less than 40. When using a Barcol hardness tester, the minimum thickness is $1/32$ inch, and the following should be applied:

- i) For a Barcol reading between 0-30: 25 readings, discard high and low and average the rest.
- ii) For a Barcol reading between 30-40: 12 readings, discard high and low and average the rest.
- iii) Barcol hardness tester cannot generally be used with epoxy.

5 **Burnout and Thickness**

The builder is to conduct and record the results of a predetermined, sufficient number of tests for glass/fiber content and thickness checks on cutouts or plugs that have been removed from laminates to make way for through-hull and through-deck fittings. The plugs are to be identified by their location in hull. Each burnout test for glass-reinforced laminates is to be made on a sample that is at least 25 mm (1 in.) in diameter. A record is to be made of the cured laminate thickness and the glass content by weight. Fiber content measurements for carbon and aramid (Kevlar) fiber reinforced laminates are to be carried out by acid tests.

Additionally, a visual inspection of the residue may be required to determine the types and the number of layers of reinforcement used in the laminate.

The cured laminate thickness, in general, is not to differ more than 15% from the thickness indicated on the approved plans.

7 **Void Content**

Where the extent of voids in the laminate has been deemed suspect by the attending Surveyor, the void content of the laminate is to be tested in accordance with ASTM D2734.

The void content is not to exceed 4%. Where the void content is in excess of 2%, additional testing may be required.

9 Laminate Properties

Determination of laminate properties (specific gravity, glass content, tensile strength and modulus, flexural strength and modulus, shear strength, and, where glass content is less than 40% or more than 60%, interlaminar shear strength) is to be made on the basis of destructive qualification tests of panels assembled by the fabricator under environmental conditions and using resin formulations and process techniques simulating the conditions, formulations and techniques to be used in actual production.

The fabricator is to lay up the test panels at an angle of about 45°. All panels are to be tested in the as-cured condition. All test results are to be reported. ABS review of laminate design will be predicated on the quality of laminate produced by the fabricator. Laminate properties derived from qualification testing of sample panels, which are to be witnessed as necessary by the Surveyor are to be included in the process description.

Test panels may be either laid up as a qualification test sample at the time of craft lay-up or may be taken from hull cut-outs or hull laminate extension tabs.

The tests associated with the laminate properties are shown in 2-6-5/Table 1.

TABLE 1
Tests for Physical Properties of FRP Laminates

<i>Type of Laminate</i>	<i>Properties</i>	<i>Test</i>
Single Skin	Flexural Strength and Modulus	ASTM D790 or D790M or ISO 178
Single Skin	Shear Strength, perpendicular and parallel to Warp	ASTM D732 85
Single Skin and Sandwich	Glass Content and Ply-by-Ply Analysis	ASTM D2584 or ISO 1172
Single Skin and Sandwich – Both Skins	Compressive Strength and Modulus	ASTM D695 or D695M or ISO 604
Single Skin and Sandwich – Both Skins	Tensile Strength and Modulus	ASTM D3039 or D638 or D638M or ISO 3268
Single Skin and Sandwich – Both Skins	Interlaminar Shear Strength	ASTM D3846
Sandwich – Core to Skin Bondline	Flatwise Tensile Test	ASTM C297
Sandwich – Core Material	Shear Strength and Modulus	ASTM C273

11 Test Results

One complete copy of the laboratory test report is to be promptly forwarded to the ABS Technical Office doing hull plan approval. Where test results are less than the laminate design properties, this is to be drawn to the attention of the Technical Office. One copy of all test results is to be filed in the classification survey report or hull certification report.

In the case of advanced composites, one copy of all test results is to be forwarded to the ABS Technical Office plan approval staff.

PART

2

CHAPTER 6 Materials for Hull Construction – Fiber Reinforced Plastics (FRP)

SECTION 6 Repair

1 General

This Section specifies the requirements for repairs of defects during construction. These details are also applicable for repair of damaged laminates due to collisions, allisions or other extreme forces.

All repair work relies on the use of proper secondary bonding technique (see 2-6-3/9.13). Therefore, additional replacement material is required to achieve the original strength of the laminate. Details of the area to be repaired, the materials to be used (resins, reinforcing materials, cores, etc.) and the repair process is to be submitted for review. Damage to the gel-coat and/or skin coat is not part of the ABS survey unless it has an adverse effect on the laminate structural layers.

3 Materials

3.1 Resins

In general, isophthalic polyester, vinyl ester or epoxy resins are to be used for all repairs. Special consideration will be given for the use of other resins, provided they are used in accordance with the manufacturer's recommendations. In all cases, the shipyard is to demonstrate to the satisfaction of the attending Surveyor that the resin is capable of bonding to the cured laminate of the craft being repaired.

3.3 Fiber Reinforcements

The original, primary fiber reinforcement is to be used in repair, whenever practical. Where alternative reinforcements are used, they are to be similar in type and weight to those being replaced. Dissimilar fiber types are not to be used in a repair unless they were part of the original laminate.

5 Repair Procedures – Single Skin Laminate

5.1 Damage Assessment

Damages can be found either by visual inspection, probing or hammer sounding of the structure. Damage can be found from indicators such as the following:

- i)* Cracked or chipped paint or abrasion of the surface
- ii)* Distortion of a structure or support member
- iii)* Unusual build-up or presence of moisture, oil or rust
- iv)* Structure that appears blistered or bubbled and feels soft to the touch
- v)* Surface and penetrating cracks, open fractures and exposed fibers
- vi)* Gouges
- vii)* Debonding of joints

For the proper inspection of suspect areas, the removal of insulation, outfitting or equipment may be required. The extent of damage is to be clearly indicated on the hull and is to be agreed upon by all parties prior to removal.

Where water is found in the laminate or core, the area is to be rinsed by fresh water and be allowed to dry for a minimum of 48 hours. Work is not to be performed on the laminate until the moisture is 0.5% by weight or less.

5.3 Removal of Damaged Laminate

5.3.1 Damage Partially Through the Thickness

For damage extending partially through the thickness of a laminate, the damaged laminate can be removed using a course grit grinder. The damaged area is then to be shaped for repair using a fine grit grinder. See 2-6-6/Figure 1a or b for preparation details.

5.3.2 Damage Through the Thickness

For damage that extends through the thickness of the laminate, the damaged area can be cut away. The laminating surfaces are to be prepared as indicated in 2-6-6/5.3.1 and 2-6-6/Figure 1a or 1b.

FIGURE 1
Scarf Joint Preparation

a) SINGLE-SIDED SCARF

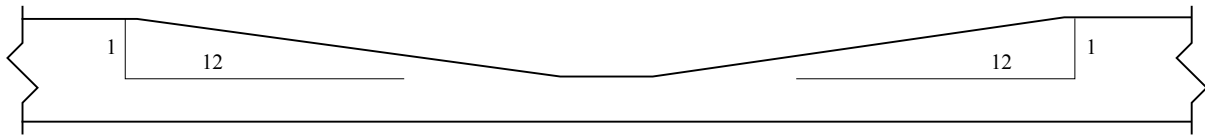

12:1 Tapered Scarf



12:1 Tapered Scarf Through Thickness Damage

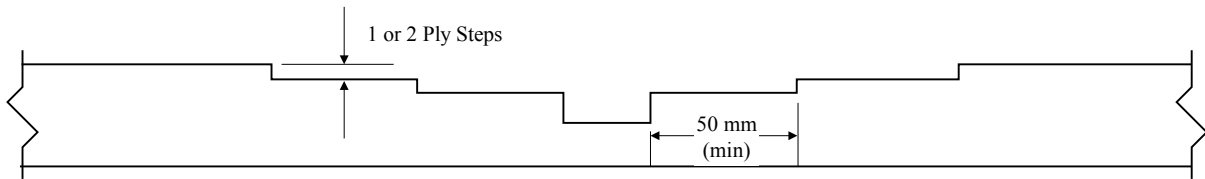

Stepped Scarf Joint

b) DOUBLE-SIDED SCARF

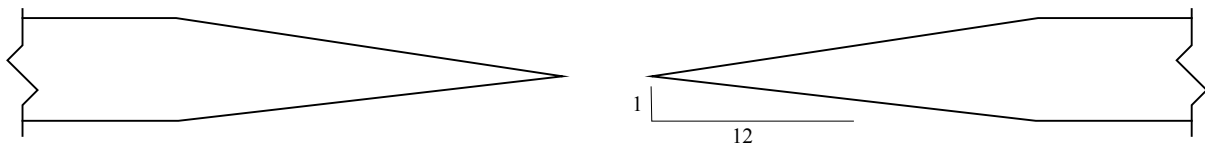

12:1 Tapered Scarf

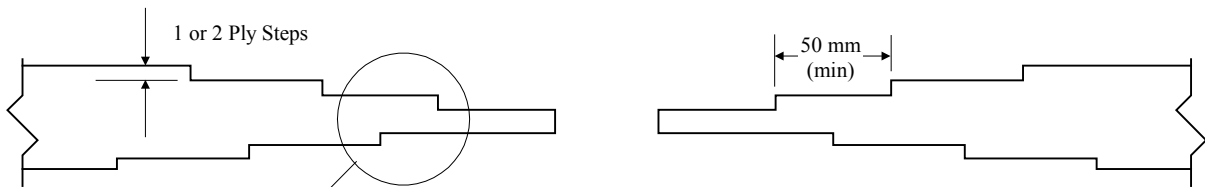

Staggered Steps Stepped Scarf Joint

5.5 Laminating Procedures

5.5.1 General

All laminating procedures consist of using secondary bonding and the requirements in 2-6-3/9.13 are applicable. Generally, the lay-up is to have the smallest ply first with each successive ply being larger, as indicated in 2-6-6/Figure 2. Each of the successive plies are to be slightly oversized and trimmed as it is being laminated in place. Care is to be taken in using undersized plies as this may create a resin pocket along the bond line. The fiber orientation is to be maintained during lamination. Alternative methods for laminating will be subject to special consideration.

FIGURE 2
Repair Sequence

BUTTED LAY-UP

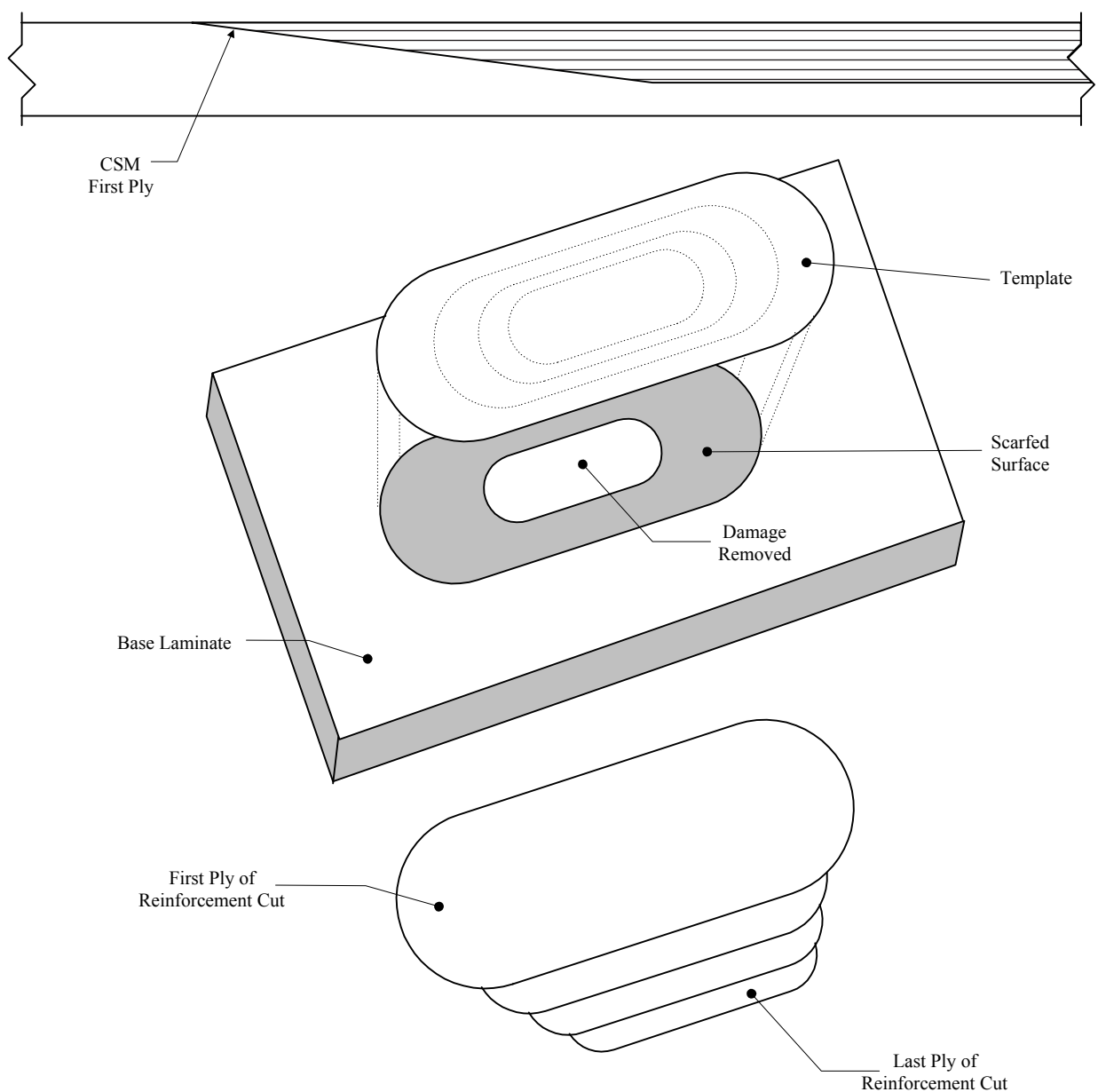

5.5.2 Overlap Requirements

Adjacent plies of reinforcement are to be overlapped when fitted with a selvage edge. Other reinforcements may be butt jointed. Edge joints in successive layers are to offset 150 mm (6 in.) relative to the underlying ply. Lengthwise joints are also to be staggered 150 mm (6 in.). The ply overlap is to be a minimum of 25 mm (1 in.). See 2-6-6/Figure 3.

FIGURE 3
Ply Overlap Requirements

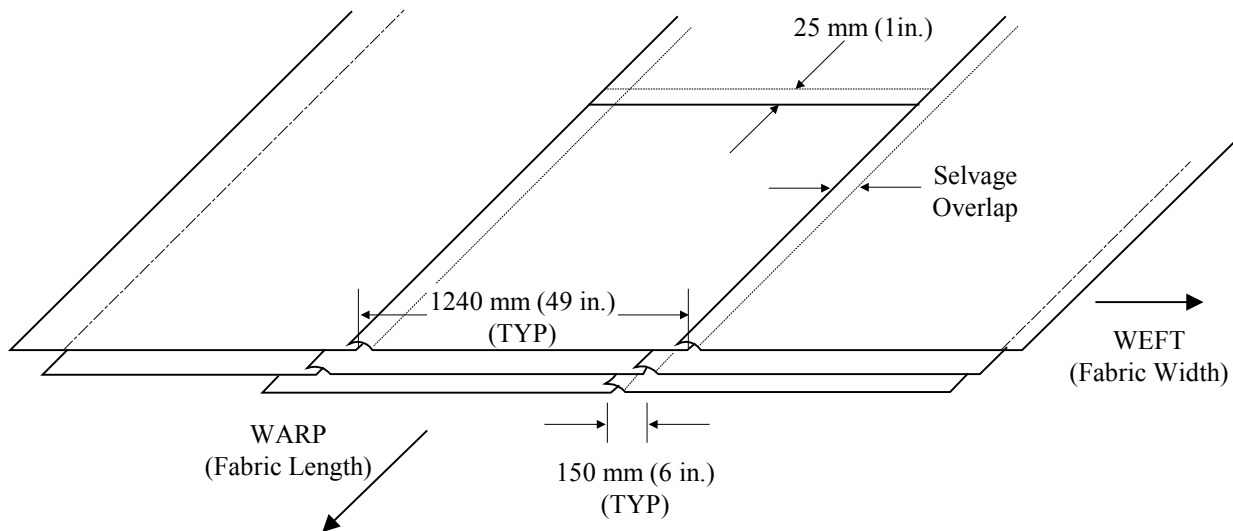

5.7 Laminating Process

In all cases, the first ply applied to the existing surface is to be chopped strand mat. This layer is to cover the entire faying surface and is to be saturated in the laminating resin. The laminating procedures, as outlined in 2-6-3/9.7, are to be followed. When lamination is required on an inclined or overhead surface, precautions are to be taken so that the wet reinforcements do not fall. Acceptable laminating repairs can be seen in 2-6-6/Figures 4 through 11.

FIGURE 4
Partially Through Thickness Defect Repair

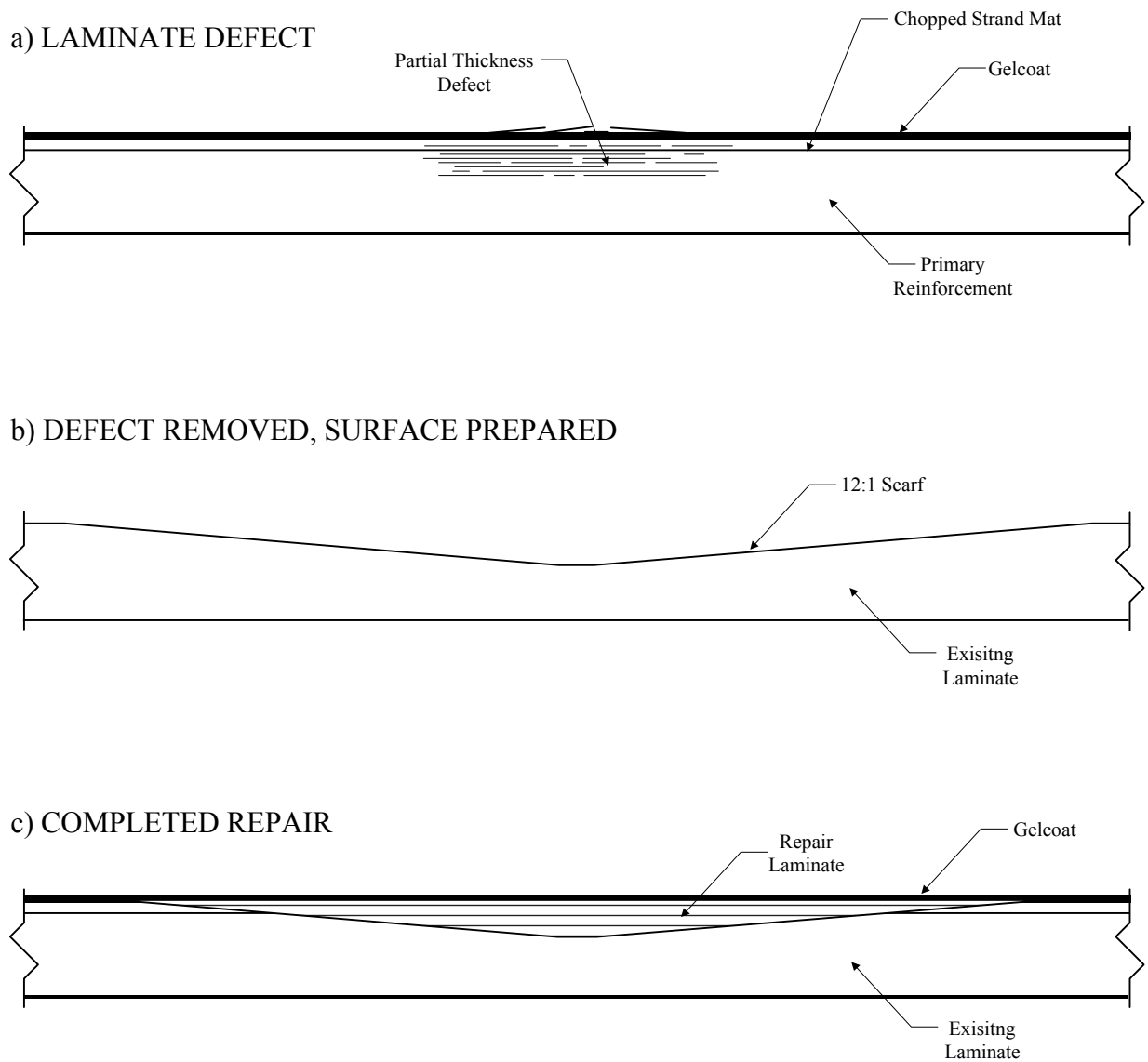
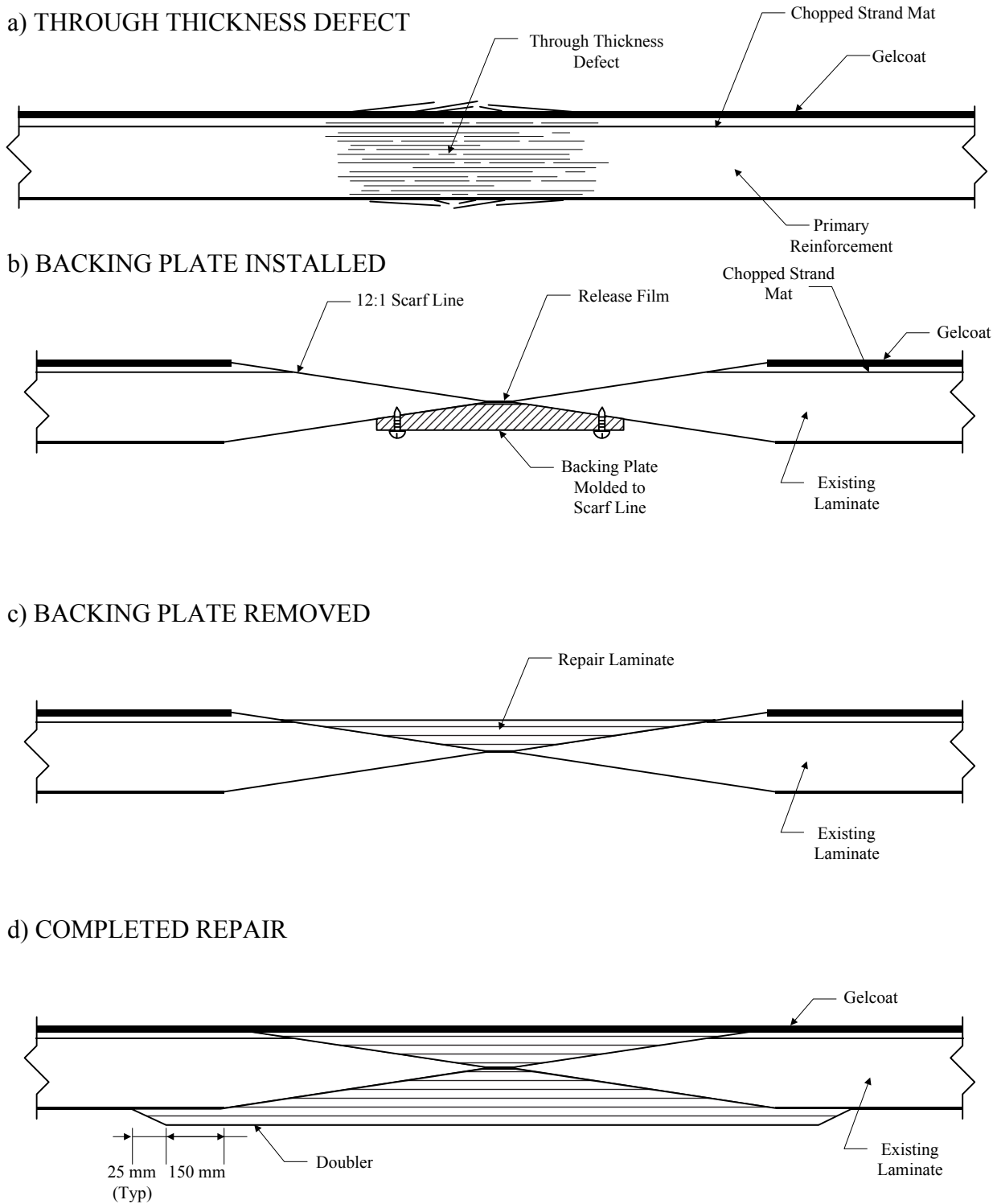
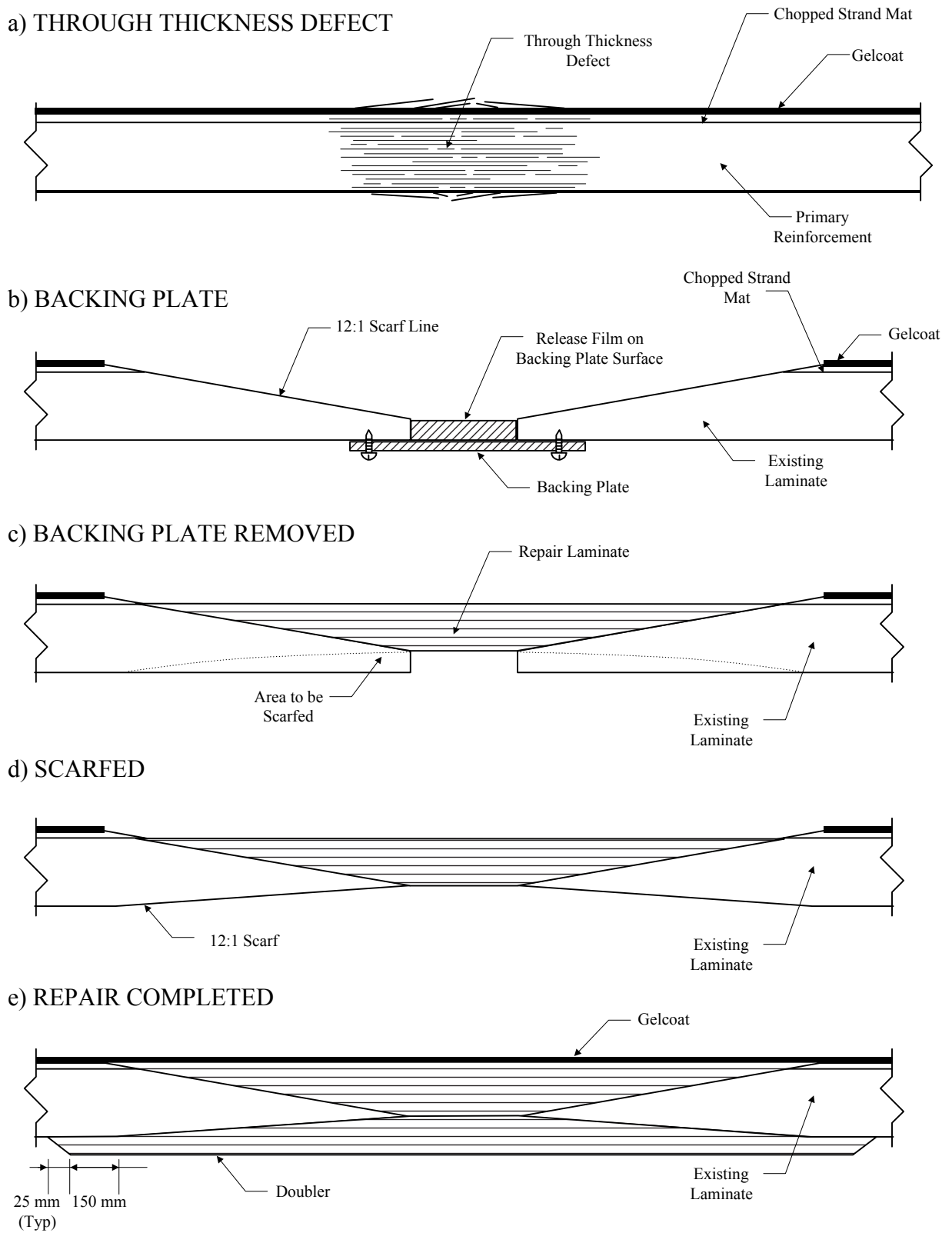

FIGURE 5
Double Sided Scarf Repair



Note: Repair shown with additional plies onto non-molded side.

FIGURE 6
One Sided Scarf Repair – Backing Plate Installation



Note: Repair shown with additional plies onto non-molded side.

FIGURE 7
Repair Using Defective Section as Backing Plate

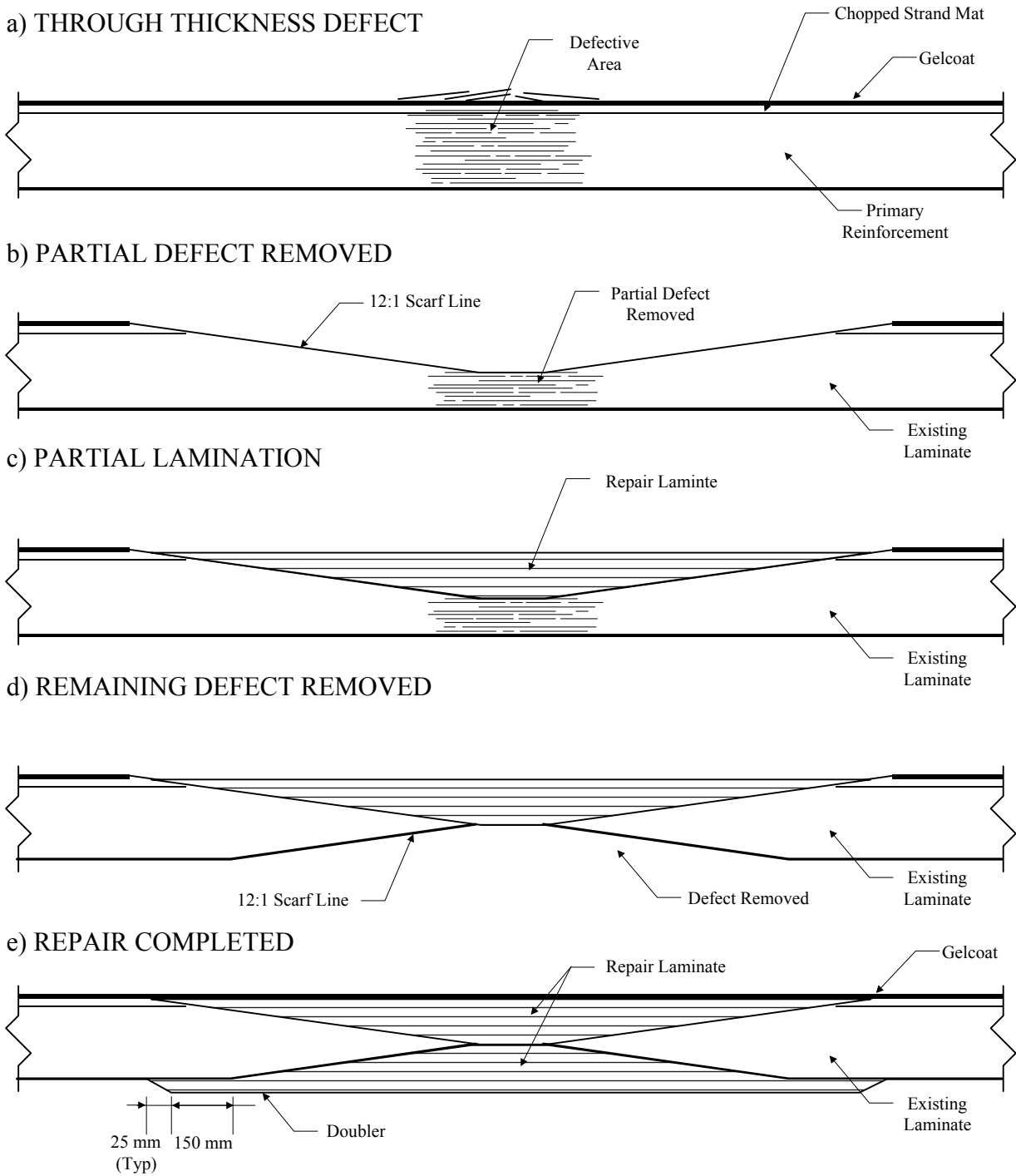

Note: Repair shown with additional plies onto non-molded side.

FIGURE 8
Single Sided Scarf Repair on Thin Laminate

a) THROUGH THICKNESS DEFECT

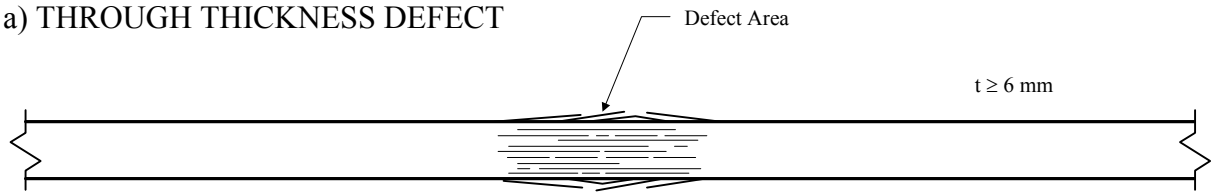

b) BACKING PLATE INSTALLATION

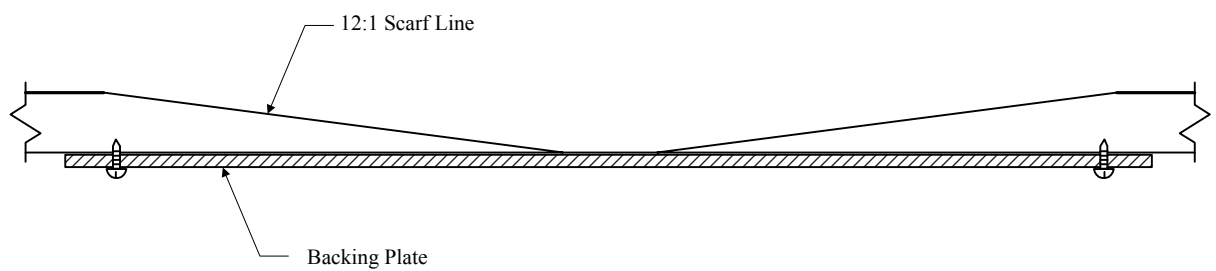

c) COMPLETED REPAIR

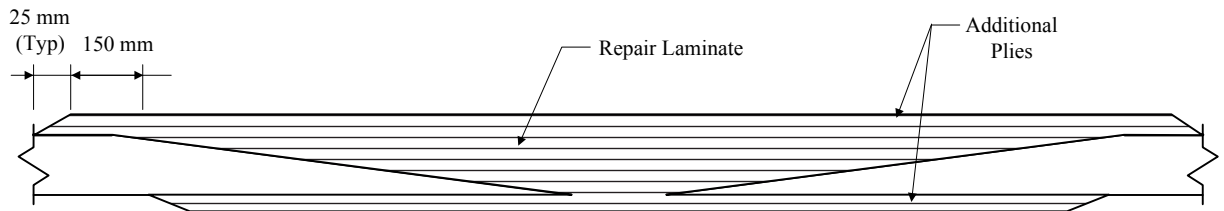

Note: Repair shown with additional plies onto non-molded side.

FIGURE 9
Backing Plate Installation – Access from One Sided Repair

a) DEFECTIVE LAMINATE

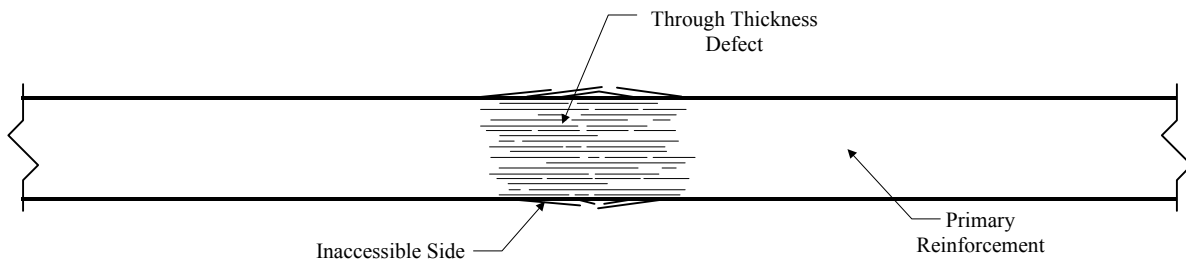

b) BACKING PLATE INSTALLATION

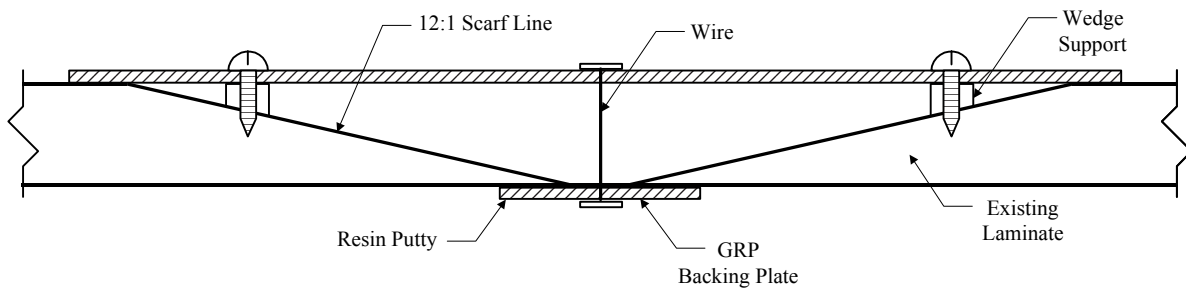

c) COMPLETED REPAIR

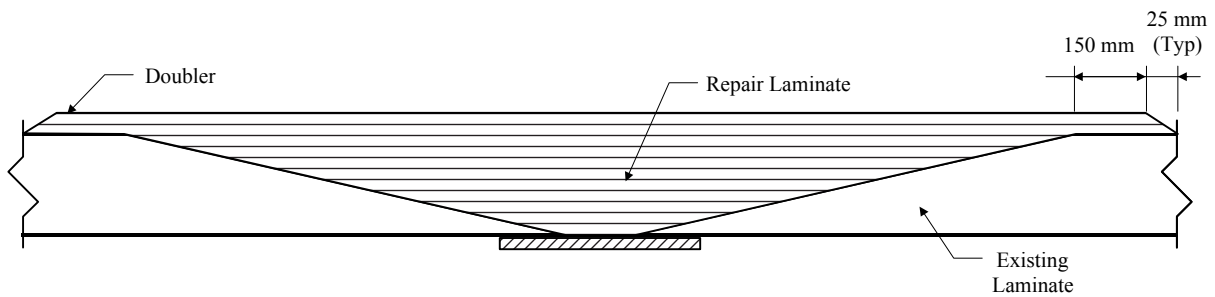

Note: Repair shown with additional plies onto non-molded side.

FIGURE 10
Repair in Way of Through Bolt Failure

a) DEFECT IN WAY OF BOLT

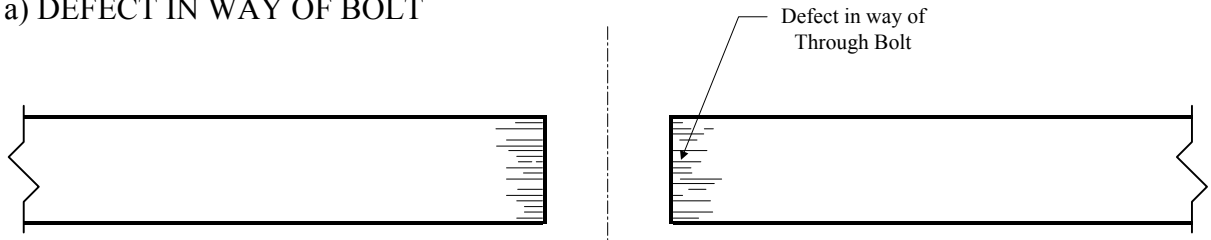

b) LAMINATE REMOVAL

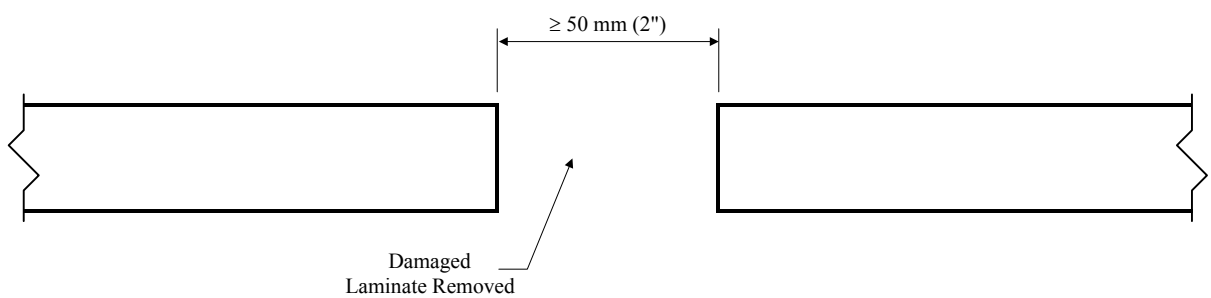

c) BACKING PLATE & FILLER

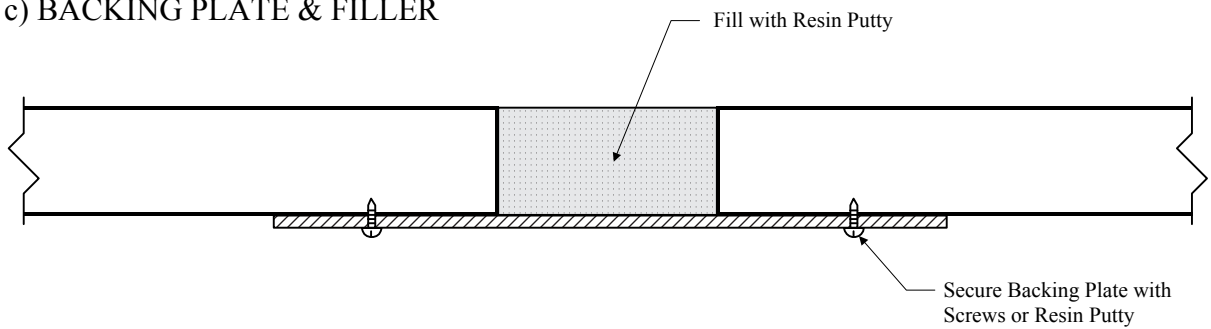

d) COMPLETED REPAIR

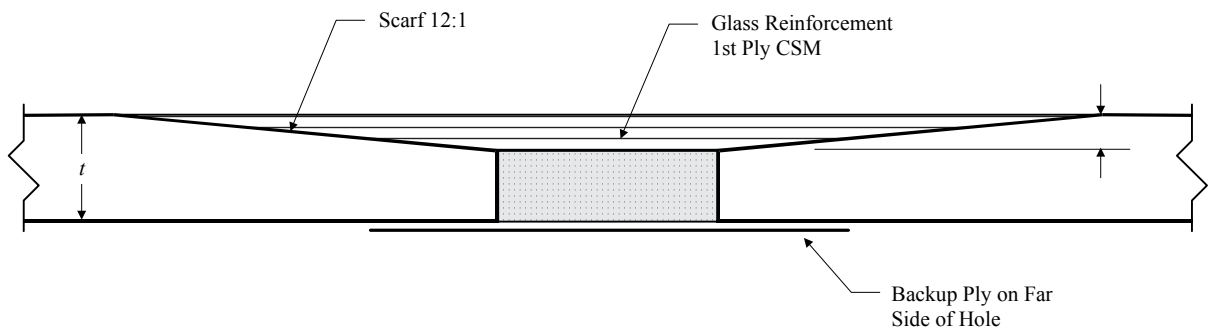
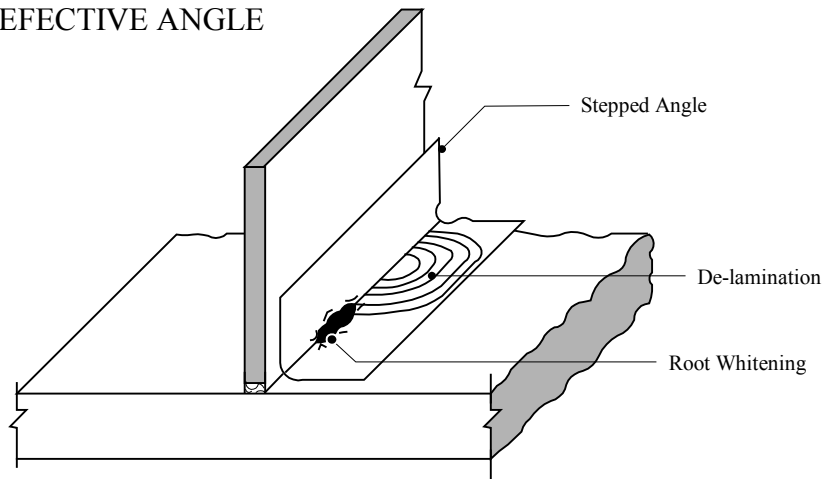
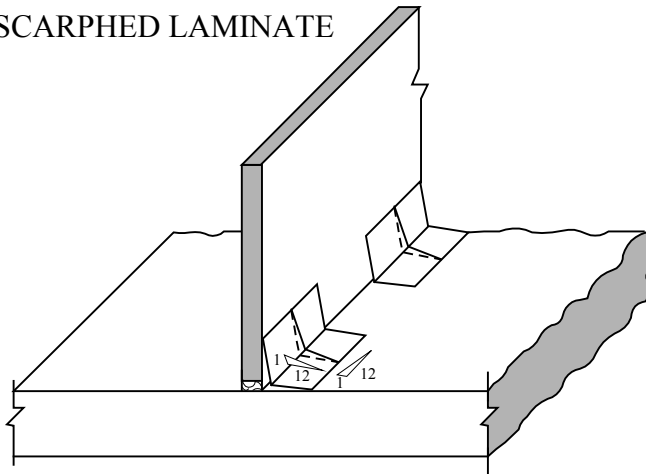

FIGURE 11
Stepped Angle Defect Repair

a) DEFECTIVE ANGLE



b) SCARPHED LAMINATE



c) COMPLETED REPAIR

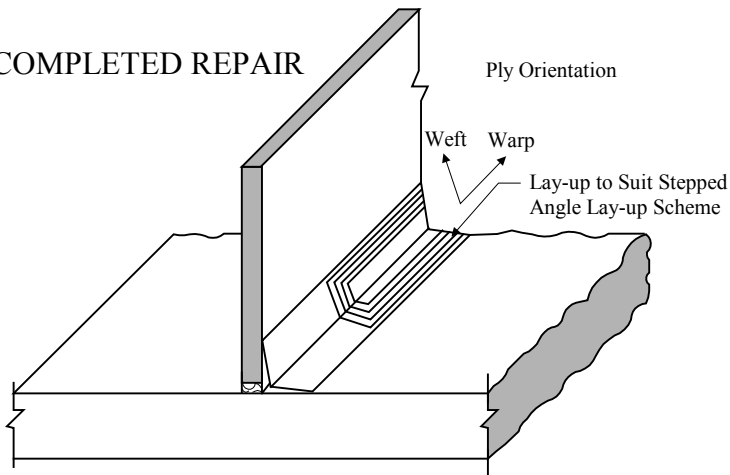

7 Repair Procedure – Sandwich Construction

7.1 Damage Assessment

The techniques outlined in 2-6-6/5.1 are to be applied to sandwich laminate. However, the extent of damage may extend far beyond the area of visible damage.

7.3 Removal of Damaged Laminate

The requirements in 2-6-6/5.3 are, in general, applicable to sandwich laminates. The cut back area will be increasingly larger, proceeding from the outer skin to the inner skin.

7.5 Laminating Procedure and Process

In general, the skins of a sandwich laminate are to be as indicated in 2-6-6/5.5 and 2-6-6/5.7. The new core is to be similar in type and density to the core that is being replaced. The new core will need to be slightly thinner than the existing core to accommodate the additional repair laminate thickness. The laminating procedure outlined in 2-6-3/9.9 is to be followed.

9 Repair Acceptance

Prior to the acceptance and painting of the repair, the area is to be inspected for the following:

- i)* There are to be no open voids, pits, cracks, crazing, delaminations or embedded contaminants in the laminate.
- ii)* There is to be no evidence of resin discoloration or other evidence of extreme exotherm.
- iii)* There is to be no dry reinforcement as indicated by white laminate
- iv)* There are to be no wrinkles in the reinforcement and no voids greater than 12 mm ($1/2$ in.)

The surface of the repair is to be smooth and conform to the surrounding surface contour. The degree of cure is to be within 10% of the required BARCOL hardness, as indicated in 2-6-5/3.